



®

ACTUATECH

ACTUATOR TECHNOLOGY

ALUMINIUM ACTUATORS

CATALOGUE

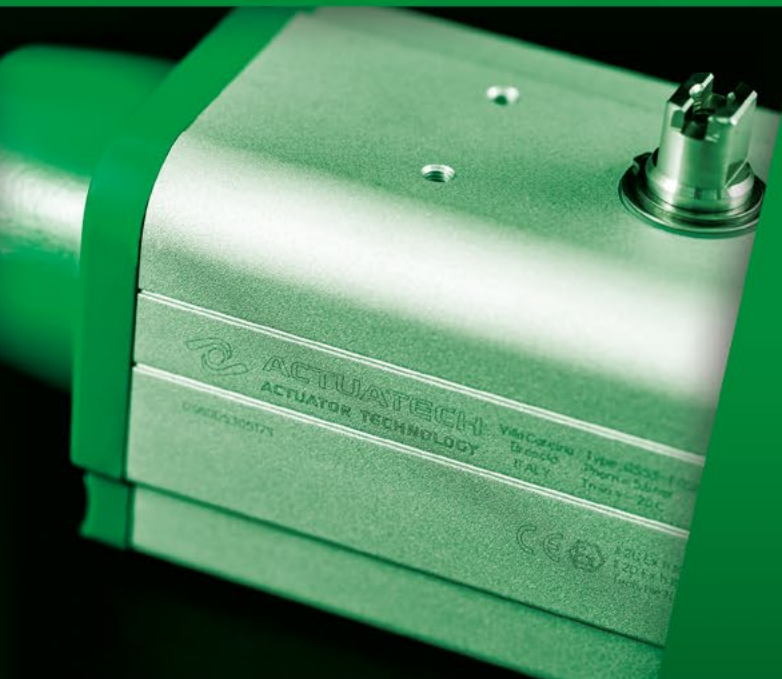

www.actuatech.com



®

ACTUATECH

ACTUATOR TECHNOLOGY

ALUMINIUM ACTUATORS

CATALOGUE



®

ACTUATECH

ACTUATOR TECHNOLOGY

Il giusto equilibrio tra uomo e ambiente migliora la qualità della vita, garantendo un mondo migliore alle generazioni future.

The right balance between human and environment improves the quality of life, ensuring a better world to future generations.



VISION & MISSION

PASSIONE
PASSION

SENSO DEL DOVERE
SENSE OF DUTY

RISPETTO
RESPECT

Garantiamo un mondo migliore ai nostri figli.
Grazie ai nostri prodotti proteggiamo
l'ambiente che ci circonda e miglioriamo
concretamente la qualità della vita rendendo
più sicuri ed affidabili gli impianti.

*We ensure a better world to our children.
Thanks to our products we take care of
the environment and we improve the
quality of life making safer and
more reliable plants.*



CERTIFICAZIONI AZIENDALI COMPANY CERTIFICATES

DNV

MANAGEMENT SYSTEM CERTIFICATE

Certificate no.: 125286-2012-AE-ITA-ACCREDIA Initial certification date: 05 November 2012 Valid: 06 November 2024 – 05 November 2027

This is to certify that the management system of **ACTUATECH S.p.A.**
Via S. Lorenzo, 70 - 25068 Villa Carcina (BS) - Italy
and the sites as mentioned in the appendix accompanying this certificate

has been found to conform to the Environmental Management System standard:
ISO 14001:2015

This certificate is valid for the following scope:
Design and production of actuators through the phases of die casting, machining, sandblasting, painting, assembly, testing and packaging (IAF 18)
Evaluated according to the requirements of Technical Regulations RT-09

Place and date:
Vimercate (MB), 25 October 2024



For the issuing office:
DNV - Business Assurance
Via Energy Park, 14 - 20871 Vimercate (MB) - Italy



Claudia Baroncini
Management Representative



Lack of fulfillment of conditions as set out in the Certification Agreement may render this Certificate invalid.
ACCREDITED UNIT: DNV Business Assurance Italy S.r.l., Via Energy Park, 14 - 20871 Vimercate (MB) - Italy - TEL: +39 039 68 99 905. www.dnv.it

DNV

MANAGEMENT SYSTEM CERTIFICATE

Certificate no.: CERT-12914-2003-AQ-MIL-SINCERT Initial certification date: 09 September 2003 Valid: 01 August 2024 – 31 July 2027

This is to certify that the management system of **ACTUATECH S.p.A.**
Via S. Lorenzo, 70 - 25068 Villa Carcina (BS) - Italy
and the sites as mentioned in the appendix accompanying this certificate

has been found to conform to the Quality Management System standard:
ISO 9001:2015

This certificate is valid for the following scope:
Design and manufacture of actuators (IAF 17)

Place and date:
Vimercate (MB), 26 July 2024



For the issuing office:
DNV - Business Assurance
Via Energy Park, 14 - 20871 Vimercate (MB) - Italy



Claudia Baroncini
Management Representative



Lack of fulfillment of conditions as set out in the Certification Agreement may render this Certificate invalid.
ACCREDITED UNIT: DNV Business Assurance Italy S.r.l., Via Energy Park, 14 - 20871 Vimercate (MB) - Italy - TEL: +39 039 68 99 905. www.dnv.it



RESPONSABILITÀ SOCIALE

SOCIAL RESPONSIBILITY

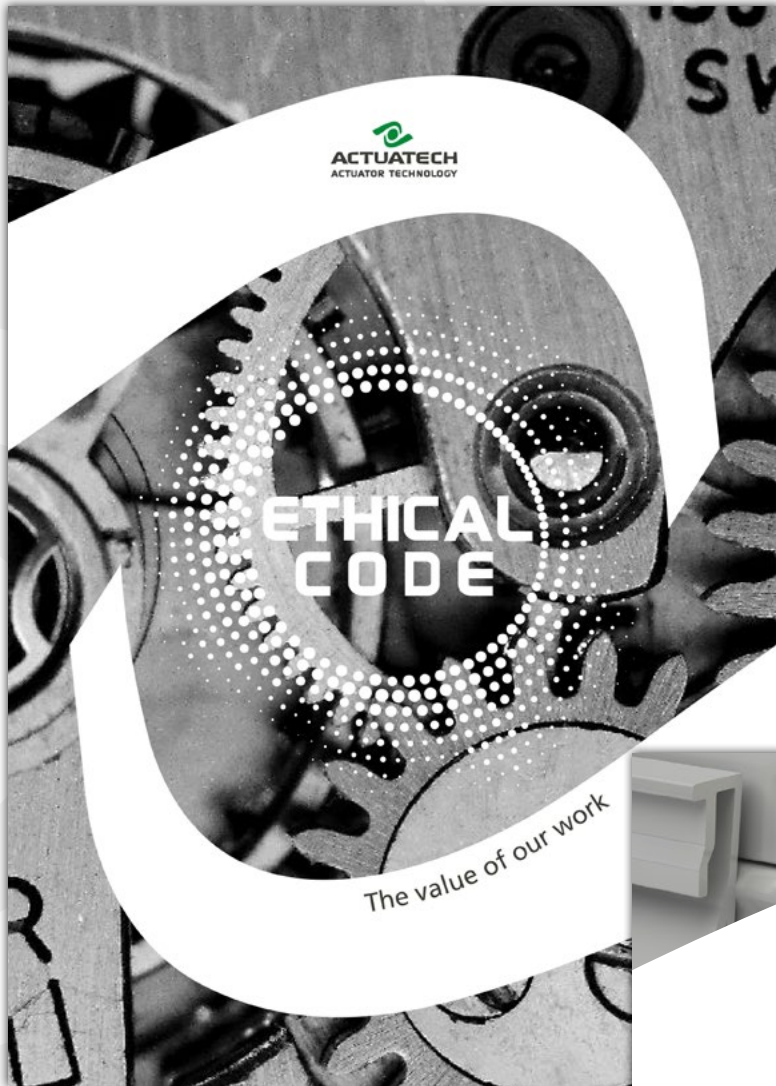



ATTUATORI IN ALLUMINIO • INDICE 1/2

Pag:

ATTUATORI PNEUMATICI

12

• Attuatore pneumatico doppio effetto "GD" in alluminio

14

Doppio effetto: GD 08 (Nm)	16
Doppio effetto: GD 15 (Nm) ÷ GD 60 (Nm)	17
Doppio effetto: GD 106 (Nm) ÷ GD 720 (Nm)	18
Doppio effetto: GD 960 (Nm) ÷ GD 1920 (Nm)	19
Doppio effetto: GD 2880 (Nm)	20
Doppio effetto: GD 3840 (Nm)	21
Doppio effetto: GD 5760 (Nm)	22
Doppio effetto: GD 8000 (Nm)	23

• Tabelle componenti attuatori pneumatici doppio effetto "GD":

Doppio effetto GD 08	24
Doppio effetto GD 15 ÷ GD 1920	25
Doppio effetto GD 2880	26
Doppio effetto GD 3840	28
Doppio effetto GD 5760	30
Doppio effetto GD 8000	32

(Continua a pag. 10)



ALUMINIUM ACTUATORS · INDEX 1/2

Pag:

PNEUMATIC ACTUATORS

12



• Aluminium double acting pneumatic actuator "GD" type

14

Double acting: GD 08 (Nm)	16
Double acting: GD 15 (Nm) ÷ GD 60 (Nm)	17
Double acting: GD 106 (Nm) ÷ GD 720 (Nm)	18
Double acting: GD 960 (Nm) ÷ GD 1920 (Nm)	19
Double acting: GD 2880 (Nm)	20
Double acting: GD 3840 (Nm)	21
Double acting: GD 5760 (Nm)	22
Double acting: GD 8000 (Nm)	23

• Pneumatic actuator components' table "GD" type:

Double acting GD 08	24
Double acting GD 15 ÷ GD 1920	25
Double acting GD 2880	26
Double acting GD 3840	28
Double acting GD 5760	30
Double acting GD 8000	32

(Continues on page 11)



ATTUATORI IN ALLUMINIO • INDICE 2/2

Pag:



• Attuatore pneumatico semplice effetto "GS" in alluminio	34
Semplice effetto: GS 15 (Nm) ÷ GS 53 (Nm)	36
Semplice effetto: GS 60 (Nm) ÷ GS 360 (Nm)	37
Semplice effetto: GS 480 (Nm) ÷ GS 960 (Nm)	38
Semplice effetto: GS 1440 (Nm)	39
Semplice effetto: GS 1920 (Nm)	40
Semplice effetto: GS 2880 (Nm)	41
Semplice effetto: GS 4000 (Nm)	42
• Tabelle componenti attuatori pneumatici semplice effetto "GS":	
Semplice effetto GS 15 ÷ GS 960	44
Semplice effetto GS 1440	46
Semplice effetto GS 1920	48
Semplice effetto GS 2880	50
Semplice effetto GS 4000	52
• Schema funzionamento attuatore pneumatico doppio effetto "GD"	54
• Schema funzionamento attuatore pneumatico semplice effetto "GS"	55
• Versioni speciali a richiesta - attuatori doppio effetto "GD"	56
• Versioni speciali a richiesta - attuatori semplice effetto "GS"	57
• Accessori attuatori pneumatici	58
• Certificazioni attuatori in alluminio 	60



ALUMINIUM ACTUATORS · INDEX 2/2

Pag:



• Aluminium spring return pneumatic actuator "GS" type	34
Spring return: GS 15 (Nm) ÷ GS 53 (Nm)	36
Spring return: GS 60 (Nm) ÷ GS 360 (Nm)	37
Spring return: GS 480 (Nm) ÷ GS 960 (Nm)	38
Spring return: GS 1440 (Nm)	39
Spring return: GS 1920 (Nm)	40
Spring return: GS 2880 (Nm)	41
Spring return: GS 4000 (Nm)	42
• Pneumatic actuator components' table "GS" type:	
Spring return GS 15 ÷ GS 960	44
Spring return GS 1440	46
Spring return GS 1920	48
Spring return GS 2880	50
Spring return GS 4000	52
• Working plane pneumatic actuator "GD" type	54
• Working plane pneumatic actuator "GS" type	55
• Special version on request - double acting "GD" actuators	56
• Special version on request - spring return "GS" actuators	57
• Pneumatic actuators Accessories	58
• Aluminium actuators certificates 	60



ATTUATORI PNEUMATICI PNEUMATIC ACTUATORS

GD DOPPIO EFFETTO *DOUBLE ACTING*

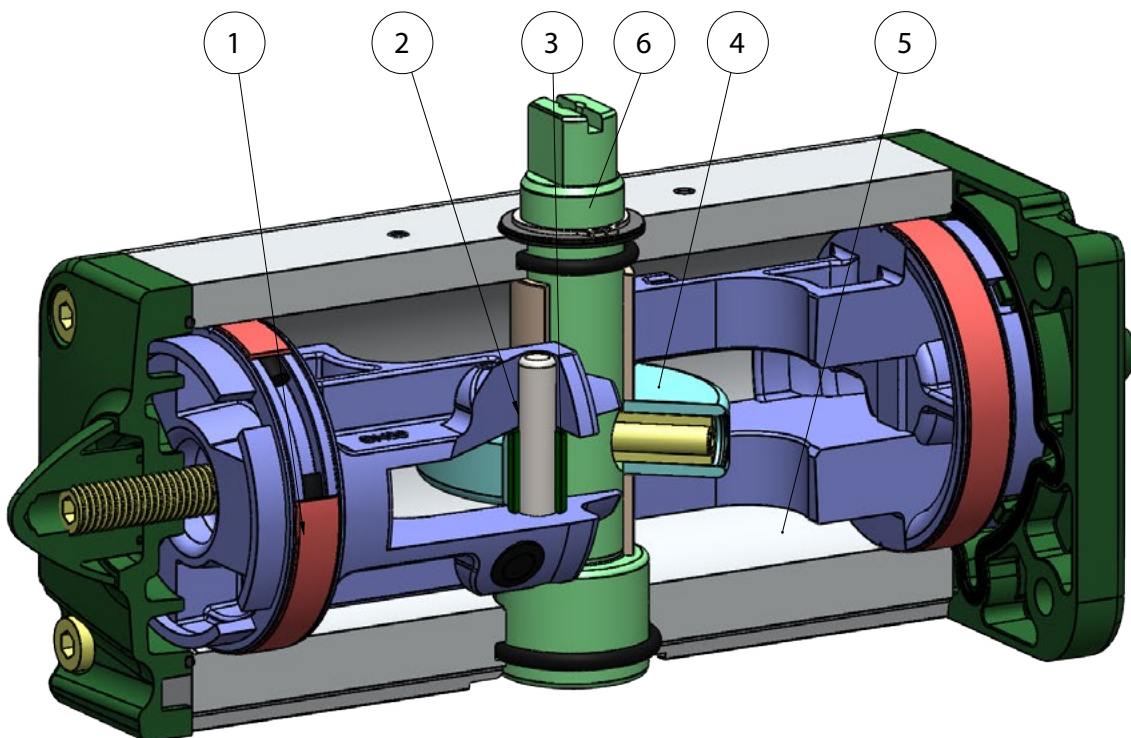

GS SEMPLICE EFFETTO *SPRING RETURN*

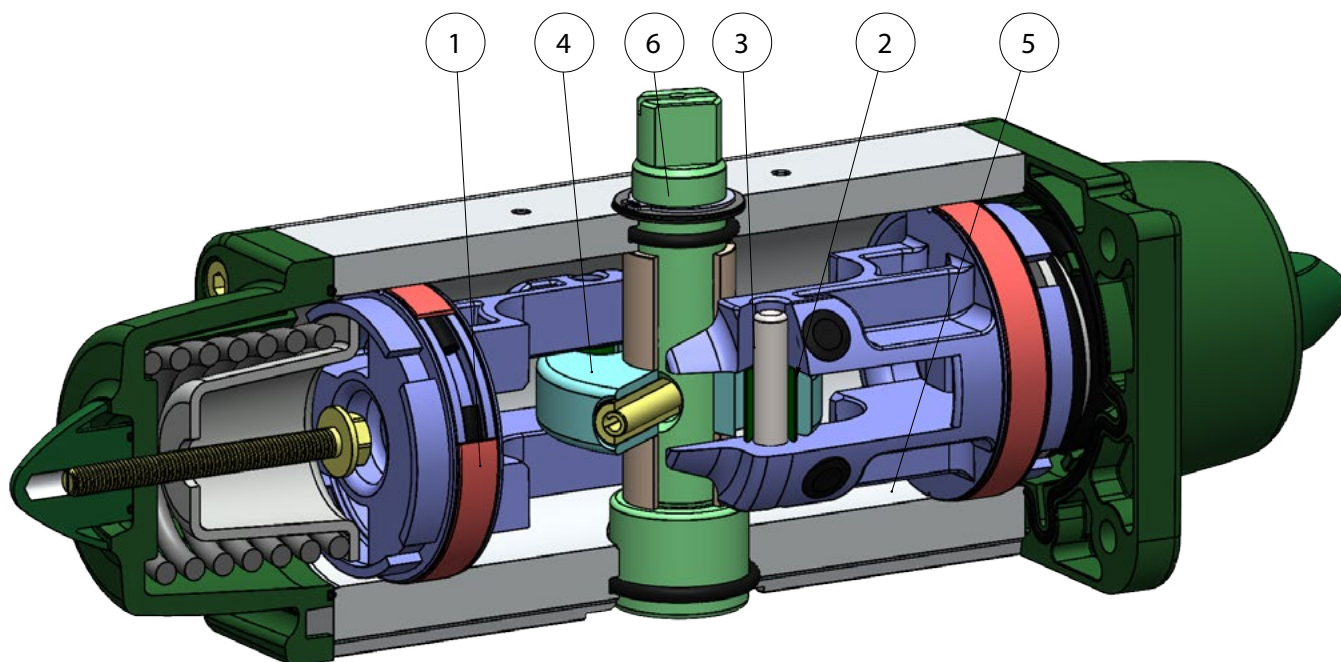



FEATURES & BENEFITS

1	<p>Fasce di tenuta e scorrimento energizzate autolubrificanti.</p> <p><i>Energized and self-lubricated strips.</i></p>	<p>Minor attrito tra pistone e cilindro.</p> <p><i>Less friction between piston and cylinder.</i></p>
		<p>Si evita l'incollaggio della guarnizione al cilindro anche dopo lunghi periodi di fermo.</p> <p><i>It prevents the bonding of the seal to the cylinder even after long periods of inactivity.</i></p>
2	<p>Slot, bussole e spine con acciaio con durezza maggiore a 50 HRC.</p> <p><i>Slots, bushes and pins made by steel with hardness higher than 50 HRC.</i></p>	<p>Maggior resistenza alle forze presenti all' interno dell'attuatore.</p> <p><i>Higher resistance to the forces inside the actuator.</i></p>
3	<p>Attrito volvente tra slot e pistone.</p> <p><i>Rolling friction between piston and slot.</i></p>	<p>Minor attrito.</p> <p><i>Less friction.</i></p>
4	<p>Scotch yoke con attrito volvente (trasformazione del movimento lineare in movimento rotatorio mediante pistone e albero privo di ingranaggi).</p> <p><i>Scotch yoke with rolling friction (transforming rotary motion into linear motion using piston and shaft without teeth/gears).</i></p>	<p>Minor attrito tra pistone e albero con conseguente minor usura dei pezzi.</p> <p><i>Reduced friction between piston and shaft with consequently less wear on the relevant parts.</i></p>
		<p>Momento torcente potenziato in fase di apertura e chiusura.</p> <p><i>Empowered Breakaway Torque (BTO & BTC).</i></p>
		<p>Minor ingombro rispetto agli attuatori pignone e cremagliera con conseguente minor spazio necessario.</p> <p><i>Smaller volume/size than rack and pinion actuators (with the same torque) therefore less space required for installation.</i></p>
		<p>Minor peso rispetto agli attuatori pignone e cremagliera (-30% Kg/Nm) con conseguenti risparmi sulla realizzazione della struttura dell'impianto.</p> <p><i>Less weight than the rack and pinion (-30% kg / Nm), with consequent savings on the construction sizing of the plant/equipment.</i></p>
5	<p>Cilindro rollato.</p> <p><i>Rolled cylinder.</i></p>	<p>Minor usura delle fascette energizzate grazie alla bassa rugosità della superficie.</p> <p><i>Less wear of the energized ties thanks to the low roughness of the surface.</i></p>
		<p>Maggiore resistenza alla corrosione.</p> <p><i>Higher corrosion resistance.</i></p>
6	<p>Albero inox.</p> <p><i>Stainless steel shaft.</i></p>	<p>Maggiore resistenza alla corrosione.</p> <p><i>Higher corrosion resistance.</i></p>
	<p>Interfaccia per elettrovalvole NAMUR integrata dal GD15.</p> <p><i>From sizes bigger than GD15, NAMUR interface for solenoid valve is already integrated.</i></p>	<p>Non richiede alcuna basetta supplementare.</p> <p><i>No need for extra plate.</i></p>
	<p>Processo produttivo interamente eseguito in ACTUATECH.</p> <p><i>100% in- house manufacturing process technology.</i></p>	<p>Massimo controllo in tutte le fasi di lavorazione.</p> <p><i>Maximum control and accuracy in all the stages of the manufacturing process.</i></p>
	<p>Certificato ATEX.</p> <p><i>ATEX Certificate.</i></p>	<p>Ne consente l'installazione in presenza di ambiente potenzialmente esplosivo.</p> <p><i>Installation is allowed in a potential explosive environment.</i></p>
	<p>Certificato fino a SIL 3.</p> <p><i>Up to SIL 3 Certified.</i></p>	<p>Elevato livello di sicurezza funzionale garantito.</p> <p><i>Guarantee of the high level of functional safety.</i></p>



ATTUATORE PNEUMATICO DOPPIO EFFETTO "GD" IN ALLUMINIO

ALUMINIUM DOUBLE ACTING PNEUMATIC ACTUATOR "GD" TYPE



DATI TECNICI

- Coppia da 8 Nm a 8000 Nm.
- Flangia d'attacco: EN ISO 5211
F03 - F04 - F05 - F07 - F10 - F12 - F14 - F16 - F25.
- Conforme alla EN 15714-3.
- Angolo di rotazione: 92° (-1°, +91°).
- Momento torcente: Direttamente proporzionale alla pressione di alimentazione; vedi tabella.
- Nel codice degli attuatori GD versione standard è indicata la coppia di spunto in Nm alla pressione di 5,6 bar.
- **ATEX in conformità alla direttiva 2014/34/UE.**

CONDIZIONI DI ESERCIZIO

- Temperatura: da -20°C a +80°C. (Versioni speciali: alta temperatura: -20°C +150°C; bassa temperatura: -50°C +60°C).
- Pressione nominale: 5,6 bar; massima di esercizio 8,4 bar (7 bar per GD 8000).
- Fluido di alimentazione: aria compressa filtrata secca non necessariamente lubrificata.
- In caso di lubrificazione usare olio non detergente, compatibile con NBR.

TECHNICAL FEATURES

- Torque from 8 Nm to 8000 Nm.
- Mounting flange according to EN ISO 5211
F03 - F04 - F05 - F07 - F10 - F12 - F14 - F16 - F25.
- In accordance with EN 15714-3
- Rotation angle: 92° (-1°, +91°)
- Torque: directly proportional to the air supply (see table).
- In the code of standard version GD actuators, it is indicated the breakaway torque in Nm at 5,6 bar air supply.
- **ATEX version in conformity with directive 2014/34/EU.**

WORKING CONDITIONS

- Temperature: from -20°C to +80°C. (Special versions: high temperature: -20°C +150°C; low temperature: -50°C +60°).
- Air supply: 5,6 bar; maximum 8,4 bar (7 bar for GD 8000).
- Actuating media: filtered dry compressed air, not necessarily lubricated.
- In case of lubricated air, either non detergent oil, NBR compatible oil, must be used.



DIAGRAMMA DEL MOMENTO TORCENTE IN FUNZIONE DELL'ANGOLO DI ROTAZIONE OUTPUT TORQUE DIAGRAM RELATED TO ROTATION ANGLE



TABELLA DEL MOMENTI TORCENTI (Nm) OUTPUT TORQUE TABLE (Nm)		$\alpha^\circ =$ ANGOLO DI ROTAZIONE $\alpha^\circ =$ ROTATION ANGLE						
MISURA SIZE	α°	3 bar	4 bar	5 bar	5,6 bar	6 bar	7 bar	8 bar
GD 08	0°	3,8	5	6,3	7	7,5	8,8	10
	45°	1,9	2,5	3,1	3,5	3,8	4,4	5
	90°	3,8	5	6,3	7	7,5	8,8	10
GD 15	0°	8	10,7	13,4	15	16,1	18,8	21,4
	50°	4	5,4	6,7	7,5	8	9,4	10,7
	90°	6,1	8,1	10,1	11,3	12,1	14,1	16,1
GD 30	0°	16,1	21,4	26,8	30	32,1	37,5	42,9
	50°	8	10,7	13,4	15	16,1	18,8	21,4
	90°	12,1	16,1	20,1	22,5	24,1	28,1	32,1
GD 45	0°	24,1	32,1	40,2	45	48,2	56,3	64,3
	50°	12,1	16,1	20,1	22,5	24,1	28,1	32,1
	90°	18,1	24,1	30,1	33,8	36,2	42,2	48,2
GD 60	0°	32,1	42,9	53,6	60	64,3	75	85,7
	50°	16,1	21,4	26,8	30	32,1	37,5	42,9
	90°	24,1	32,1	40,2	45	48,2	56,3	64,3
GD 106	0°	56,8	75,7	94,6	106	113,6	132,5	151,4
	50°	28,4	37,9	47,3	53	56,8	66,3	75,7
	90°	42,9	57,1	71,4	80	85,7	100	114,3
GD 120	0°	64,3	85,7	107,1	120	128,6	150	171,4
	50°	32,1	42,9	53,6	60	64,3	75	85,7
	90°	48,2	64,3	80,4	90	96,4	112,5	128,6
GD 180	0°	96,4	128,4	160,7	180	192,9	225	257,1
	50°	48,2	64,3	80,4	90	96,4	112,5	128,6
	90°	72,3	96,4	120,5	135	144,6	168,8	192,9
GD 240	0°	128,6	171,4	214,3	240	257,1	300	342,9
	50°	64,3	85,7	107,1	120	128,6	150	171,4
	90°	96,4	128,6	160,7	180	192,9	225	257,1
GD 360	0°	192,9	257,1	321,4	360	385,7	450	514,3
	50°	96,4	128,6	160,7	180	192,9	225	257,1
	90°	144,6	192,9	241,1	270	289,3	337,5	385,7
GD 480	0°	257,1	342,9	428,6	480	514,3	600	685,7
	50°	128,6	171,4	214,3	240	257,1	300	342,9
	90°	192,9	257,1	321,4	360	385,7	450	514,3
GD 720	0°	385,7	514,3	642,9	720	771,4	900	1028,6
	50°	192,9	257,1	321,4	360	385,7	450	514,3
	90°	289,3	385,7	482,1	540	578,6	675	771,4
GD 960	0°	514,3	685,7	857,1	960	1028,6	1200	1371,4
	50°	257,1	342,9	428,6	480	514,3	600	685,7
	90°	385,7	514,3	642,9	720	771,4	900	1028,6
GD 1440	0°	771,4	1028,6	1285,7	1440	1542,9	1800	2057,1
	50°	385,7	514,3	642,9	720	771,4	900	1028,6
	90°	578,6	771,4	964,3	1080	1157,1	1350	1542,9
GD 1920	0°	1028,6	1371,4	1714,3	1920	2057,1	2400	2742,9
	50°	514,3	685,7	857,1	960	1028,6	1200	1371,4
	90°	771,4	1028,6	1285,7	1440	1542,9	1800	2057,1
GD 2880	0°	1542,9	2057,1	2571,4	2880	3085,7	3600	4114,3
	50°	771,4	1028,6	1285,7	1440	1542,9	1800	2057,1
	90°	1157,1	1542,9	1928,6	2160	2314,3	2700	3085,7
GD 3840	0°	2057,1	2742,9	3428,6	3840	4114,3	4800	5485,7
	50°	1028,6	1371,4	1714,3	1920	2057,1	2400	2742,9
	90°	1542,9	2057,1	2571,4	2880	3085,7	3600	4114,3
GD 5760	0°	3085,7	4114,3	5142,9	5760	6171,4	7200	8228,6
	50°	1542,9	2057,1	2571,4	2880	3085,7	3600	4114,3
	90°	2314,3	3085,7	3857,1	4320	4628,6	5400	6171,4
GD 8000	0°	4285,7	5714,3	7142,9	8000	8571,4	10000	---
	50°	2142,9	2857,1	3571,4	4000	4285,7	5000	---
	90°	3214,3	4285,7	5357,1	6000	6428,6	7500	---



Doppio effetto: GD 08 (Nm)
Double acting: GD 08 (Nm)

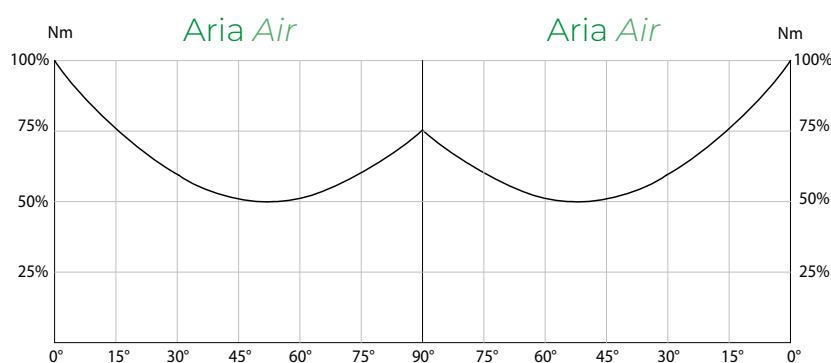
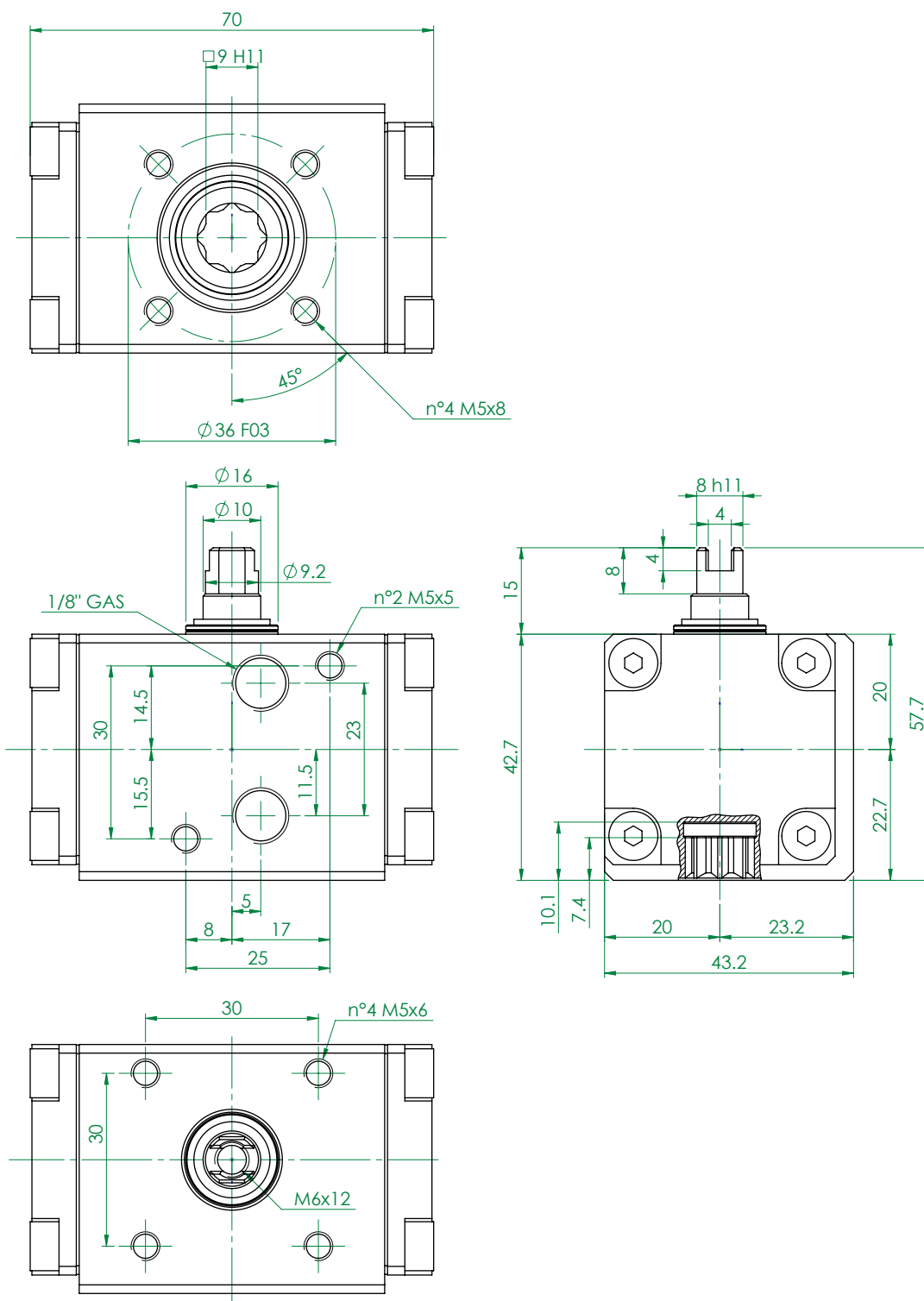

SCHEDA TECNICA DATA SHEET

Codice Code		GD000080309S
Peso Weight	Kg	0,29
Volume aria Air volume	dm ³ /cycle	0,04
Guarnizioni di ricambio Spare seals		KGDI0010



Doppio effetto: **GD 15 (Nm) ÷ GD 60 (Nm)** Double acting: **GD 15 (Nm) ÷ GD 60 (Nm)**

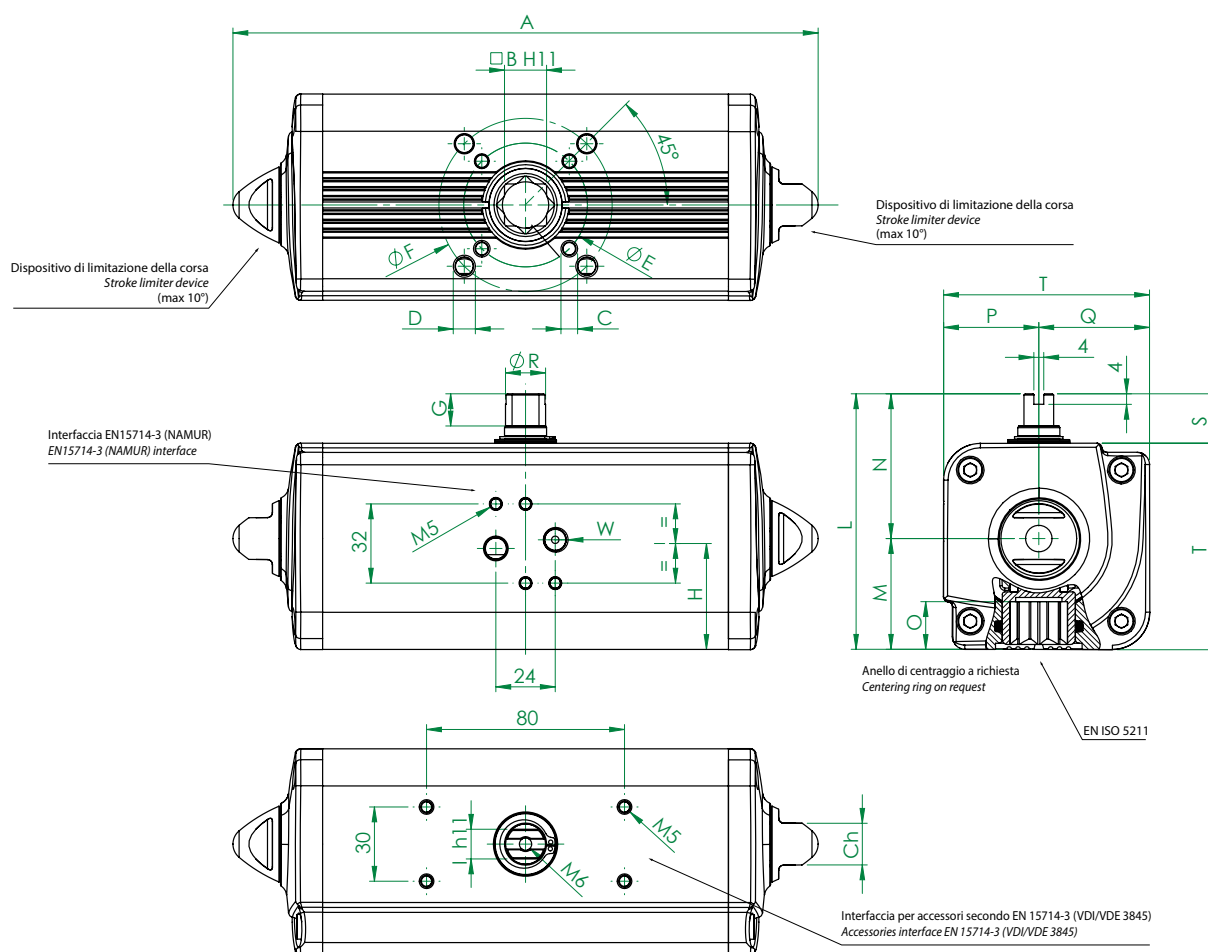

SCHEDA TECNICA DATA SHEET

Codice Code	GD0001503115	GD0001504115	GD0003003115	GD0003004115	GD0004504115	GD0004503115	GD0006004145	GD0006005145
Spare seals	KGGI0012		KGGI0014		KGGI0015		KGGI0016	
Misura Size	GD 15		GD 30		GD 45		GD 60	
ISO	F03	F04	F03/F05	F04	F04	F03/F05	F04	F05/F07
A	159,1	159,1	174,3	174,3	188,5	188,5	198,1	198,1
B	11	11	11	11	11	11	14	14
C x depth	M5x8	M5x8	M5x8	M5x8	M5x8	M5x8	M5x8	M6x9
D x depth	-	-	M6x9	-	-	M6x9	-	M8x12
E	36	42	36	42	42	36	42	50
F	-	-	50	-	-	50	-	70
G	10	10	10	10	13	13	13	13
H	26,8	26,8	30,3	30,3	32,5	32,5	35,7	35,7
I	8	8	9	9	10	10	10	10
L	72,2	72,2	79,2	79,2	84,5	84,5	90,4	90,4
M	28	28	31,5	31,5	34,5	34,5	37,7	37,7
N	44,2	44,2	47,7	47,7	50	50	52,7	52,7
O	13,2	13,2	13,2	13,2	13,2	13,2	16,5	16,5
P	24,2	24,2	27,7	27,7	30	30	32,7	32,7
Q	28	28	31,5	31,5	34,5	34,5	37,7	37,7
R	9,2	9,2	10,9	10,9	12,7	12,7	14,5	14,5
S	20	20	20	20	20	20	20	20
T	52,2	52,2	59,2	59,2	64,5	64,5	70,4	70,4
W (Gas)	1/8"	1/8"	1/8"	1/8"	1/8"	1/8"	1/8"	1/8"
Ch	13	13	13	13	13	13	13	13
Weight (Kg)	0,75	0,75	1	1	1,2	1,2	1,6	1,6
Air (dm ³ /cycle)	0,09	0,09	0,17	0,17	0,24	0,24	0,31	0,31

H = CENTRO DEI FISSAGGI Basetta H = CENTER OF PLATE'S FIXING



Doppio effetto: **GD 106 (Nm) ÷ GD 720 (Nm)** Double acting: **GD 106 (Nm) ÷ GD 720 (Nm)**

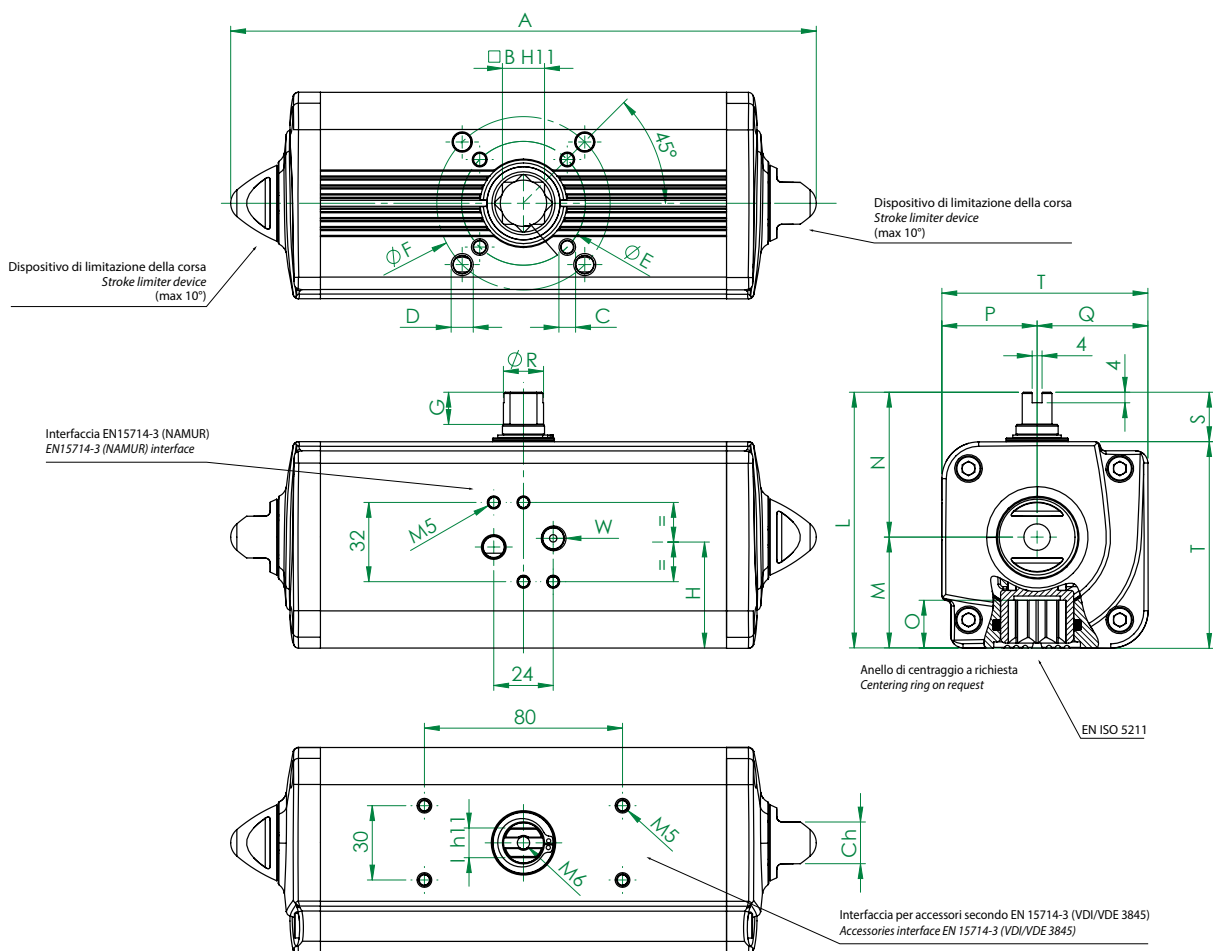

SCHEDA TECNICA DATA SHEET

Codice Code	GD001060517S	GD001200517S	GD001800722S	GD002400722S	GD003600722S	GD004801027S	GD007201027S
Spare seals	KGGI0060	KGGI0018	KGGI0019	KGGI0020	KGGI0021	KGGI0022	KGGI0023
Misura Size	GD 106	GD 120	GD 180	GD 240	GD 360	GD 480	GD 720
ISO	F05/F07	F05/F07	F07/F10	F07/F10	F07/F10	F10/F12	F10/F12
A	237,1	257,4	289,9	313,6	339,3	387,7	433
B	17	17	22	22	22	27	27
C x depth	M6x9	M6x9	M8x12	M8x12	M8x12	M10x15	M10x15
D x depth	M8x12	M8x12	M10x15	M10x15	M10x15	M12x18	M12x18
E	50	50	70	70	70	102	102
F	70	70	102	102	102	125	125
G	13	13	16	17	19	19	19,5
H	42,8	44,8	54,5	58,1	60	57,4	61,5
I	12	12	15	15	19	19	22
L	103,3	107	137,5	141,1	148	164,9	178
M	44,8	46,8	56,5	60,1	62	72,9	78,5
N	58,5	60,2	81	81	86	92	99,5
O	19,3	19,3	24,8	24,8	24,3	29,5	29,5
P	38,5	40,2	51	51	56	62	69,5
Q	44,8	46,8	56,5	60,1	62	72,9	78,5
R	16,2	18	20,2	22,5	25,5	29	31,8
S	20	20	30	30	30	30	30
T	83,3	87	107,5	111,1	118	134,9	148
W (Gas)	1/8"	1/8"	1/8"	1/8"	1/8"	1/4"	1/4"
Ch	17	17	22	22	22	27	27
Weight (Kg)	2,5	2,6	4,6	5,4	6,5	9,6	12
Air (dm ³ /cycle)	0,55	0,63	0,96	1,28	1,87	2,45	3,76

H = CENTRO DEI FISSAGGI Basetta H = CENTER OF PLATE'S FIXING



Doppio effetto: GD 960 (Nm) ÷ GD 1920 (Nm)
Double acting: GD 960 (Nm) ÷ GD 1920 (Nm)

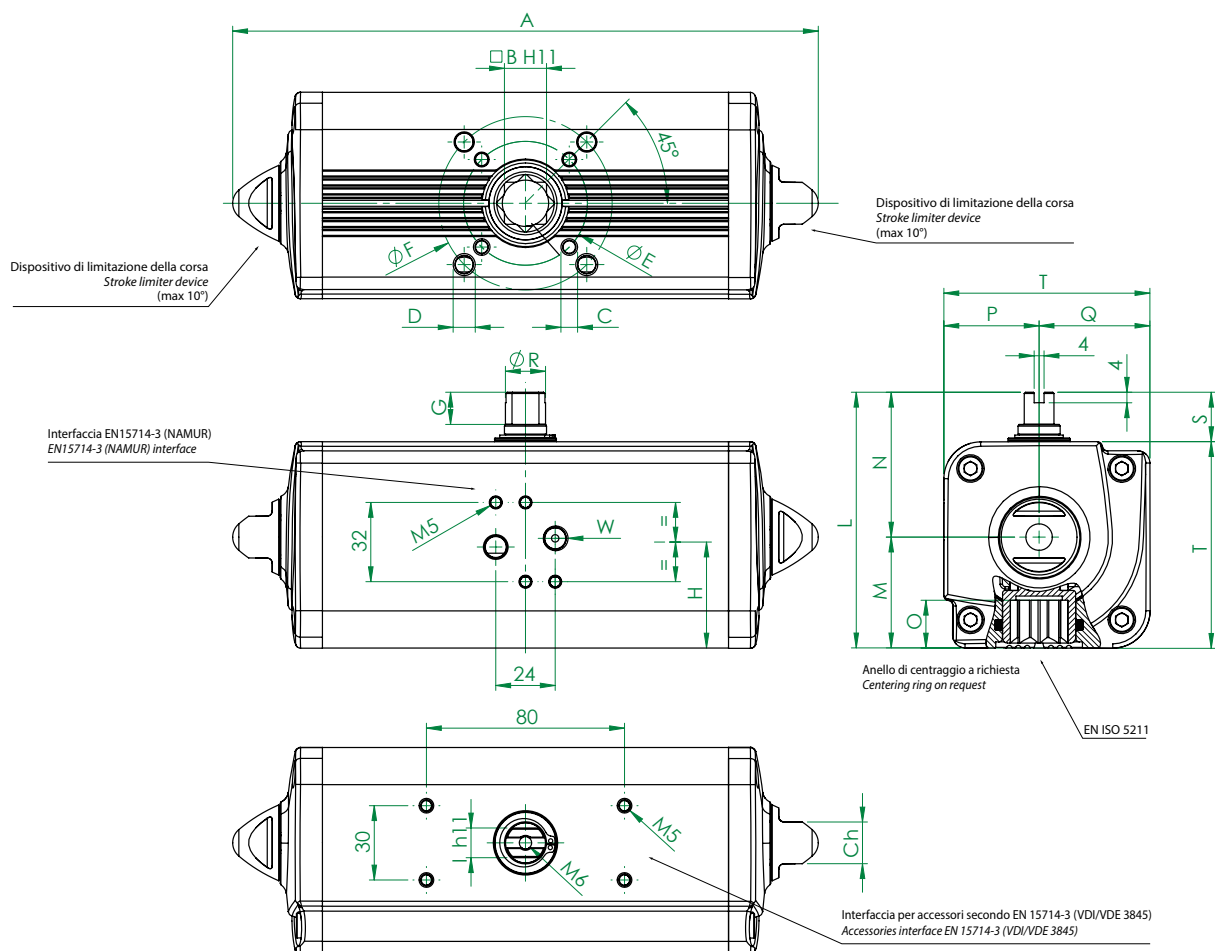

SCHEDA TECNICA DATA SHEET

Codice Code	GD009601236S	GD009601436S	GD014401236S	GD014401436S	GD019201646S	GD019201446S
Spare seals	KGGI0024		KGGI0025		KGGI0026	
Misura Size	GD 960		GD 1440		GD 1920	
ISO	F10/F12	F14	F12	F14	F12/F16	F14
A	479,4	479,4	567	567	601	601
B	36	36	36	36	46	46
C x depth	M10x15	M16x24	M12x18	M16x24	M12x18	M16x24
D x depth	M12x18	-	-	-	M20x30	-
E	102	140	125	140	125	140
F	125	-	-	-	165	-
G	19,5	19,5	19,5	19,5	18,5	18,5
H	78	78	86,5	86,5	99,2	99,2
I	24	24	27	27	32	32
L	198	198	216	216	237,7	237,7
M	93,5	93,5	101,5	101,5	114,7	114,7
N	104,5	104,5	114,5	114,5	123	123
O	38,5	38,5	38,5	38,5	48,5	48,5
P	74,5	74,5	84,5	84,5	93	93
Q	93,5	93,5	101,5	101,5	114,7	114,7
R	36,5	36,5	41	41	46	46
S	30	30	30	30	30	30
T	168	168	186	186	207,7	207,7
W (Gas)	1/4"	1/4"	1/4"	1/4"	1/4"	1/4"
Ch	27	27	36	36	36	36
Weight (Kg)	17,4	17,4	23,4	23,4	32	32
Air (dm ³ /cycle)	5,07	5,07	8,04	8,04	10,50	10,50

H = CENTRO DEI FISSAGGI BASETTA H = CENTER OF PLATE'S FIXING



Doppio effetto: **GD 2880 (Nm)**

Double acting: **GD 2880 (Nm)**

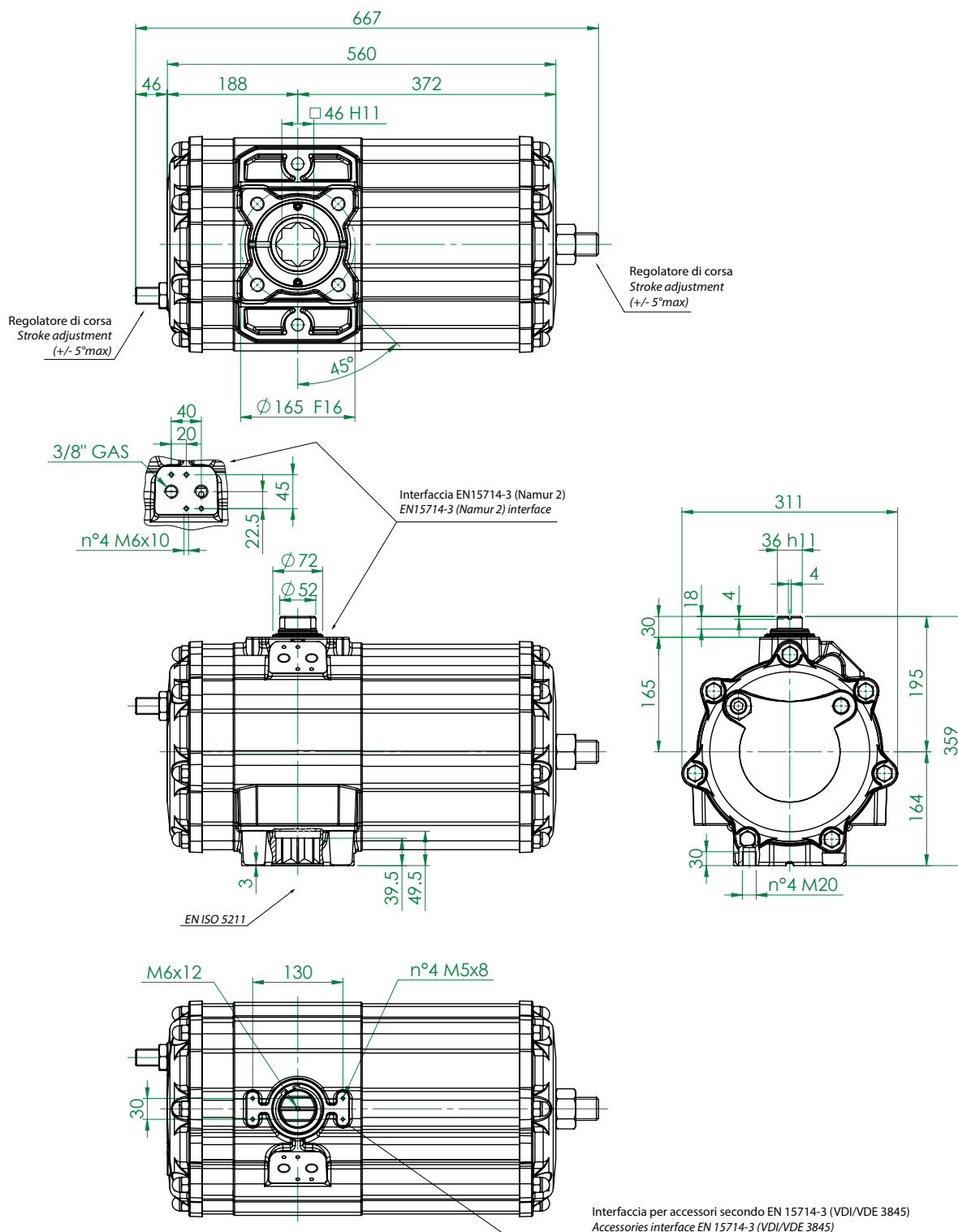

SCHEDA TECNICA DATA SHEET

Codice Code		GD0288016465
Peso Weight	Kg	55,4
Volume aria Air volume	dm ³ /cycle	24,43
Guarnizioni di ricambio Spare seals		KGDI1035



Doppio effetto: **GD 3840 (Nm)**

Double acting: **GD 3840 (Nm)**

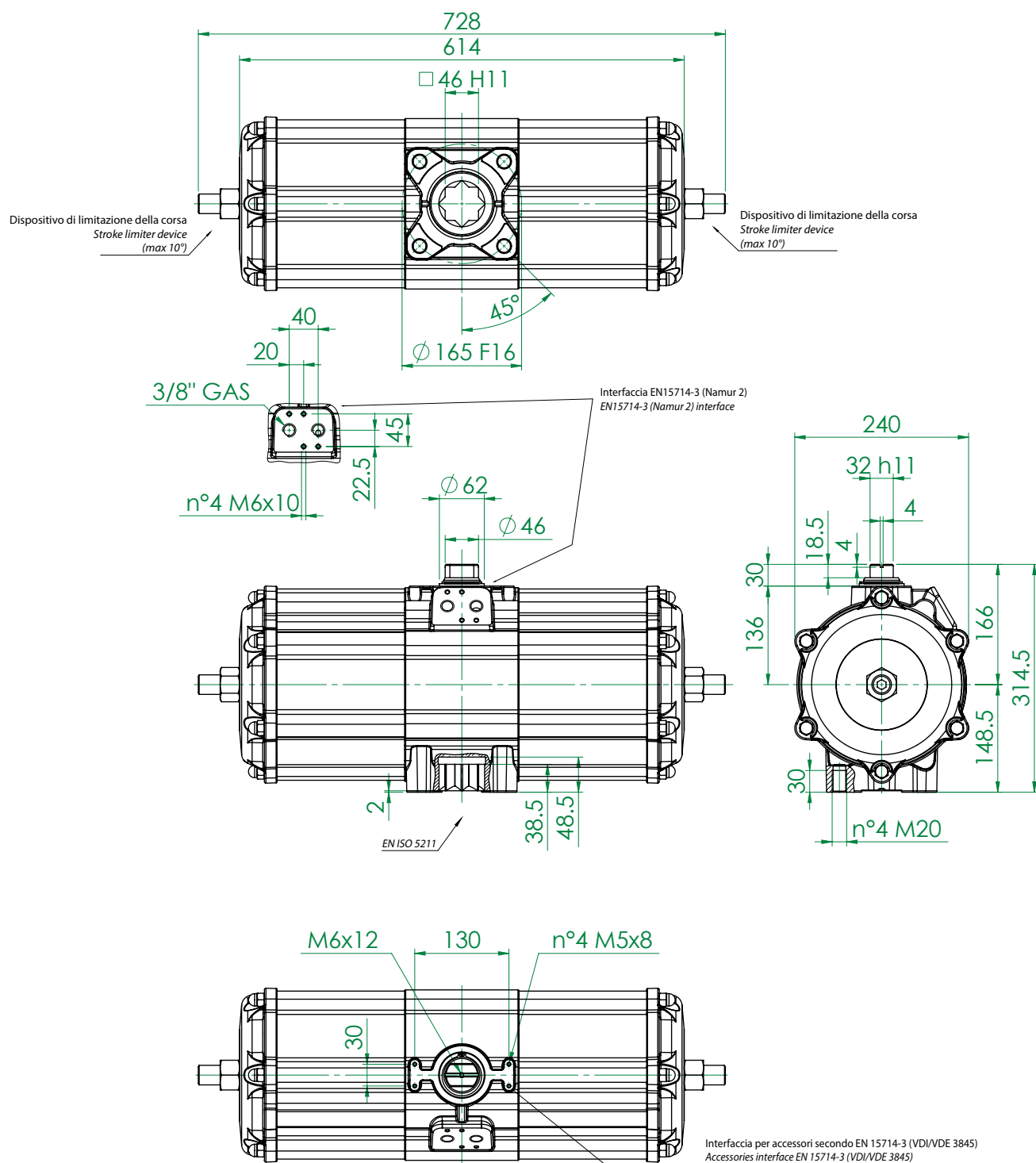

Disponibile versione con doppia regolazione della corsa (+/- 5°max) con codice GD0384016A04.
Available version with double stroke adjustment (+/- 5°max) with code GD0384016A04.

SCHEDA TECNICA		DATA SHEET	
Codice Code		GD038401646S	
Peso Weight	Kg	49,0	
Volume aria Air volume	dm ³ /cycle	21,85	
Guarnizioni di ricambio Spare seals		KGDI0030	



Doppio effetto: **GD 5760 (Nm)** Double acting: **GD 5760 (Nm)**

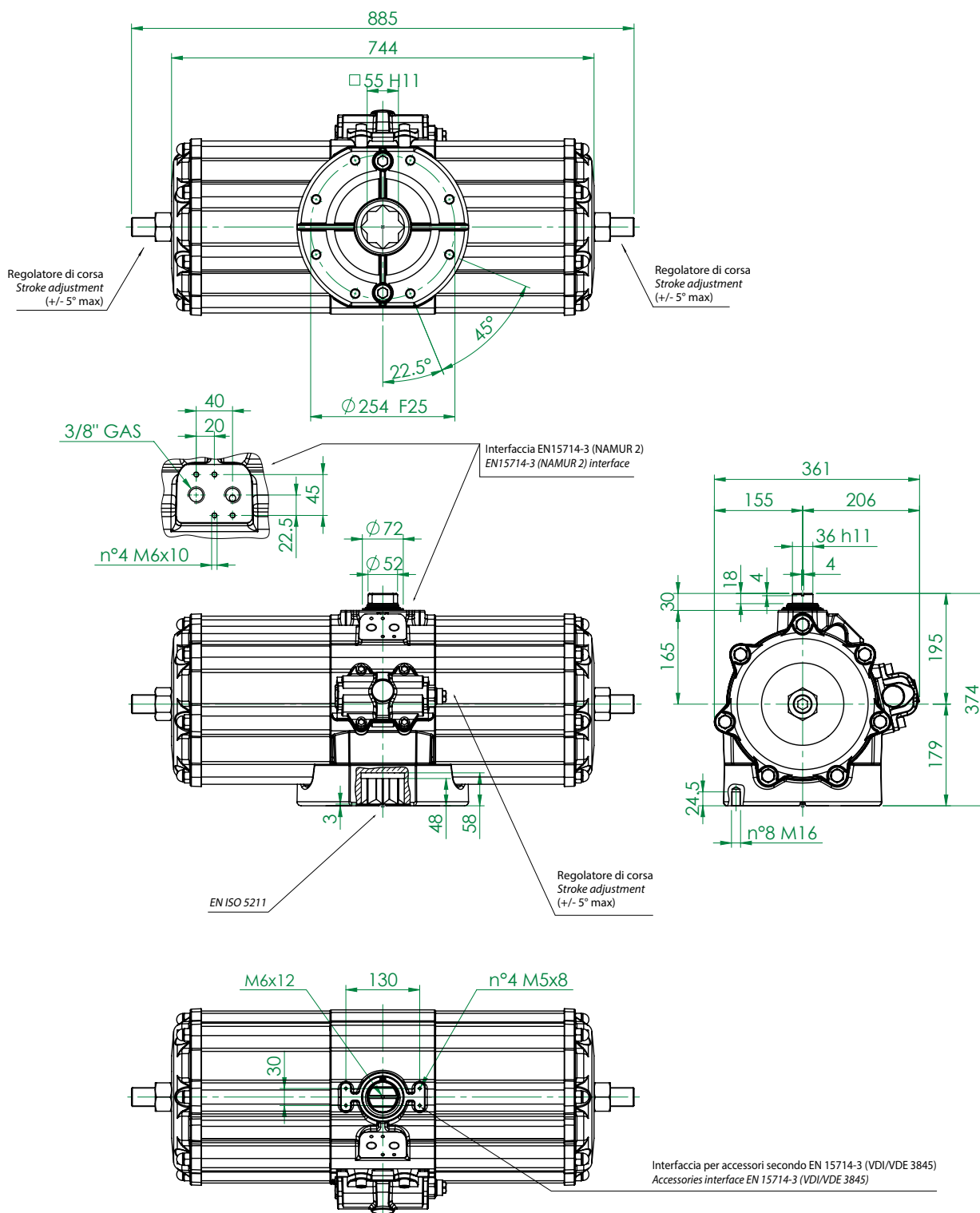

SCHEDA TECNICA DATA SHEET	
Codice Code	GD0576025555
Peso Weight	Kg 85,5
Volume aria Air volume	dm ³ /cycle 35,22
Guarnizioni di ricambio Spare seals	KGDI2035



Doppio effetto: **GD 8000 (Nm)**

Double acting: **GD 8000 (Nm)**

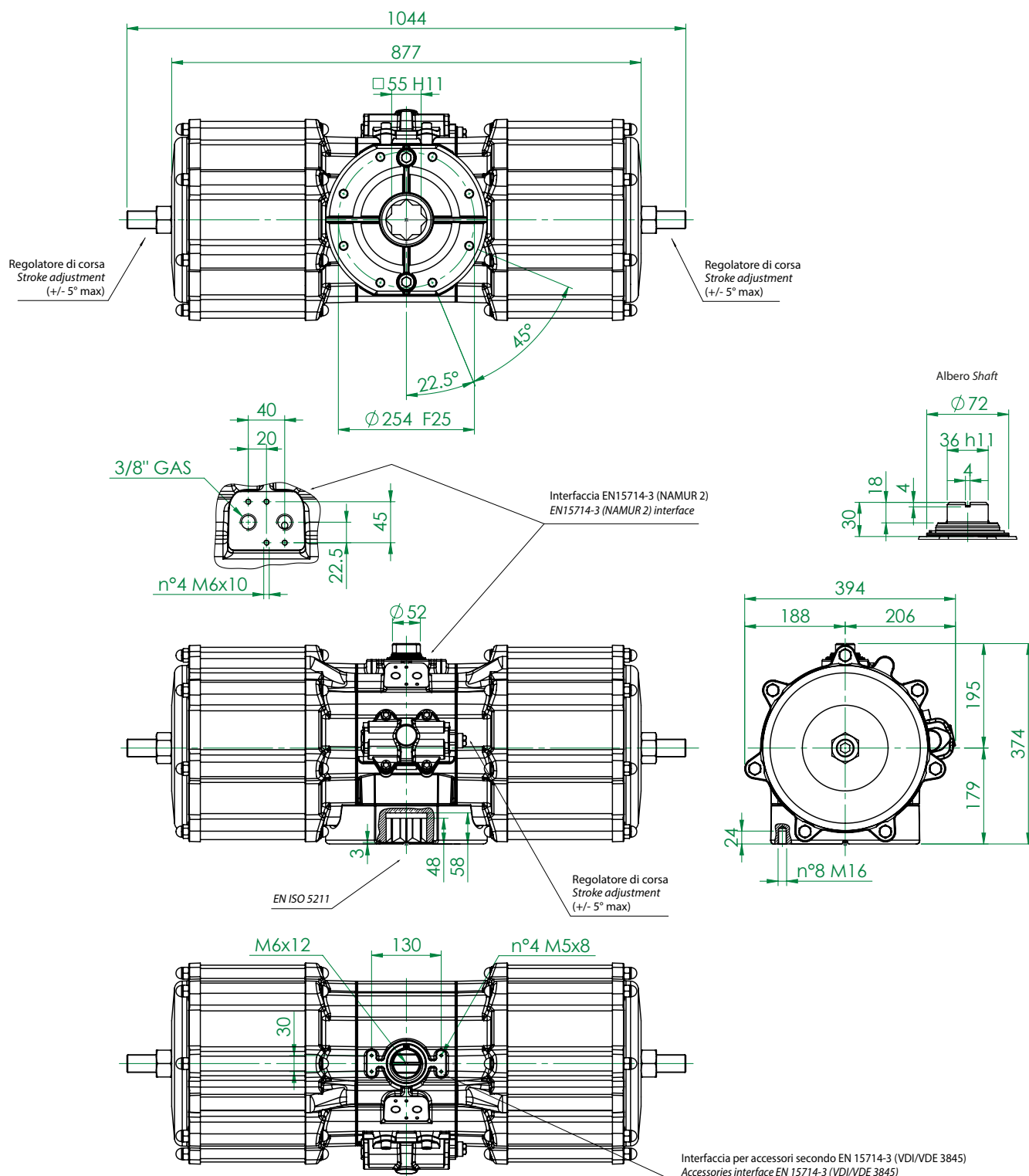

SCHEDA TECNICA DATA SHEET

Codice Code		GD0800025555
Peso Weight	Kg	105,5
Volume aria Air volume	dm ³ /cycle	55,70
Guarnizioni di ricambio Spare seals		KGDI1040



COMPONENTI DOPPIO EFFETTO: GD 08
DOUBLE ACTING COMPONENTS: GD 08

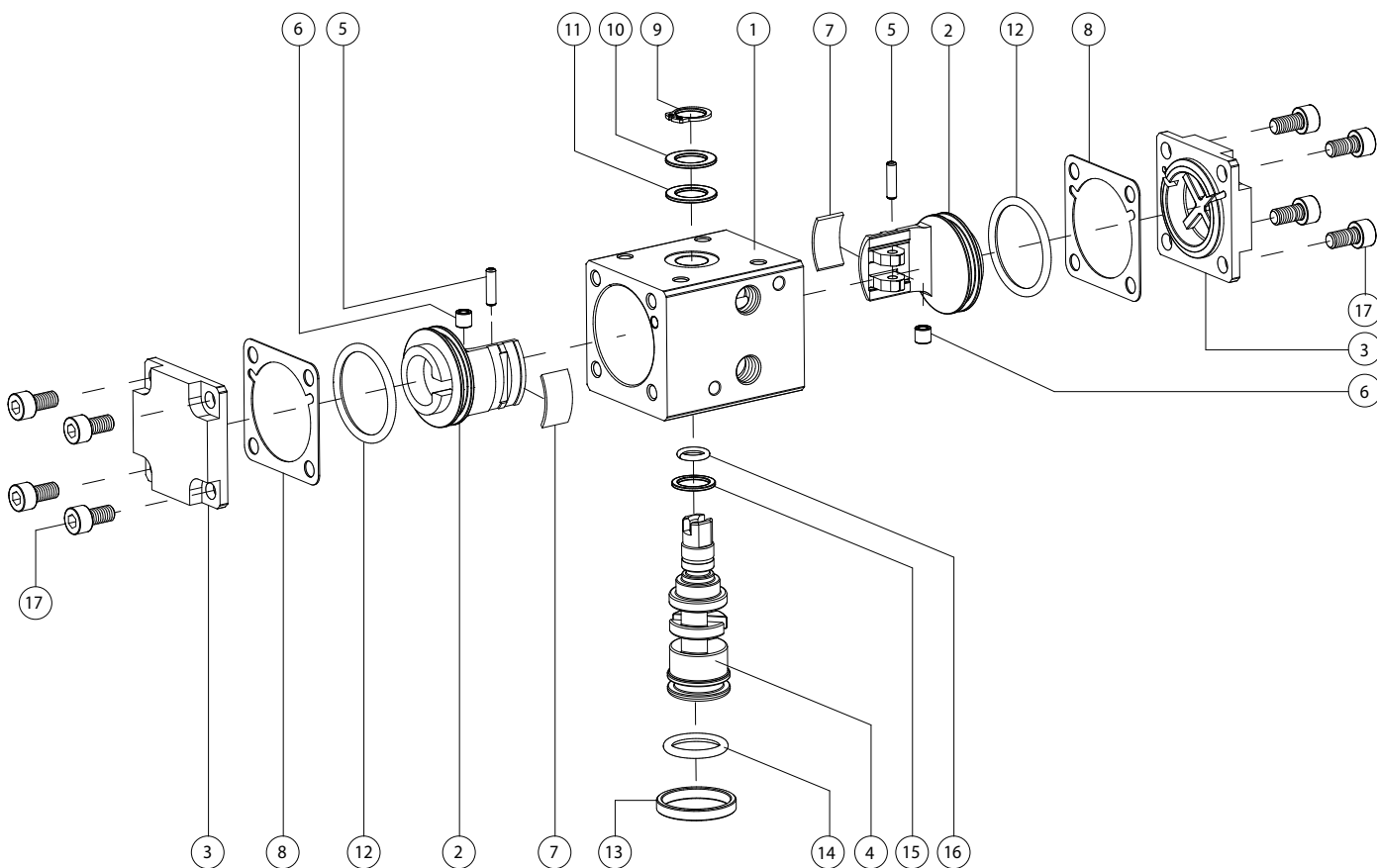

MATERIALI MATERIALS			
Pos	Denominazione Denomination	Q.ty	Materiale Material
1	Cilindro Cylinder	1	Lega di alluminio Aluminium alloy
2	Pistone Piston	2	Lega di alluminio Aluminium alloy
3	Tappo DA Cap DA	2	Lega di alluminio Aluminium alloy
4	Albero Shaft	1	Lega di acciaio Steel alloy
5	Perno Sleeve	2	Lega di acciaio Steel alloy
6	Bussola acciaio Steel Bush	2	Lega di acciaio Steel alloy
7*	Fascia di supporto Support band	2	Resina acetica Acetalic resins
8*	Guarnizione di tenuta O-ring	2	Gomma Nitrilica Nitrilic rubber
9	Seeger	1	Acciaio Inox Stainless steel
10	Rondella di spessoramento Washer	1	Acciaio Inox Stainless steel
11*	Anello supporto est. Ext. support ring	1	Resina acetica Acetalic resins
12*	O-ring pistone O-ring	2	Gomma nitrilica Nitrilic rubber
13	Anello centraggio Center ring (OPTIONAL)	1	Lega di alluminio Aluminium alloy
14*	O-ring albero inferiore O-ring	1	FKM
15*	Anello supporto int. Int.support ring	1	Resina acetica Acetalic resins
16*	Oring Albero superiore O-ring	1	FKM
17	Viti Screw	8	Acciaio inox Stainless steel

* Particolari del kit di ricambio Components of spare part kit



COMPONENTI DOPPIO EFFETTO: GD 15 ÷ GD 1920

DOUBLE ACTING COMPONENTS: GD 15 ÷ GD 1920

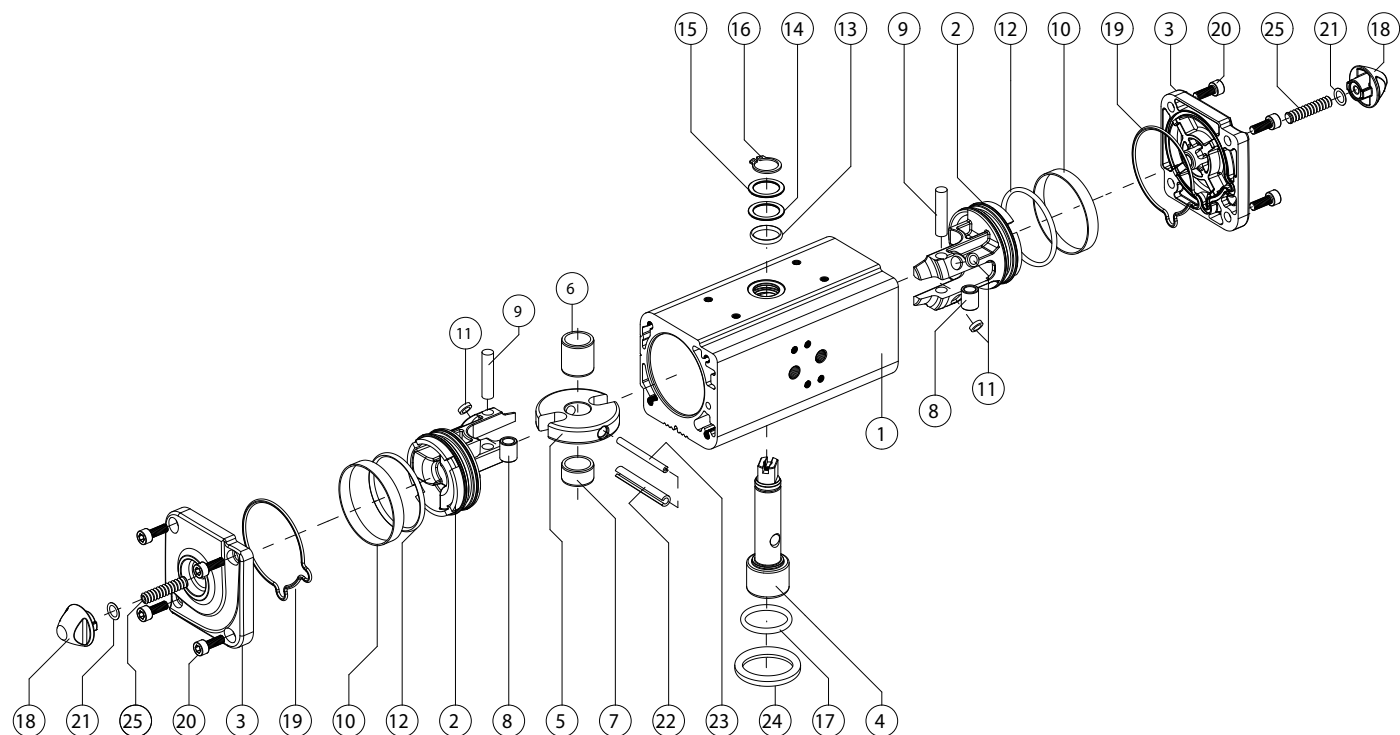

MATERIALI MATERIALS			
Pos	Denominazione Denomination	Q.ty	Materiale Material
1	Cilindro Cylinder	1	Lega di alluminio Aluminium alloy
2	Pistone Piston	2	Lega di alluminio Aluminium alloy
3	Tappo Cap	2	Lega di alluminio Aluminium alloy
4	Albero Shaft	1	Acciaio inox Stainless steel
5	Forcella Scotch yoke	1	Lega di acciaio Steel alloy
6	Bussola di scorrimento Support bush	1	Resina acetale Acetalic resin
7	Supporto albero Shaft support	1	Resina acetale Acetalic resin
8	Bussola Bush	2	Lega di acciaio Steel alloy
9	Perno Rotative sleeve	2	Lega di acciaio Steel alloy
10*	Anello di tenuta Dynamic seal	2	Poliuretano Polyurethan
11*	Dischetto di supporto Piston's suport	4	P.T.F.E. carbo-graphite filled
12*	O-ring pistone O-ring	2	Gomma nitrilica Nitrilic rubber
13	O-ring albero superiore O-ring (upper sealing shaft)	1	FKM
14	Anello di supporto esterno External support ring	1	Resina acetale Acetalic resins
15	Rondella di spessoramento Washer	1	Acciaio inox Stainless steel
16	Seeger	1	Acciaio inox Stainless steel
17	O-ring albero inferiore O-ring (lower sealing shaft)	1	FKM
18	Dado Nut	2	Lega di alluminio Aluminium alloy
19*	O-ring del tappo End-cap O-ring	2	Gomma nitrilica Nitrilic rubber
20	Viti Screws	8	Acciaio inox Stainless steel
21*	O-ring	2	Gomma nitrilica Nitrilic rubber
22	Spina elastica esterna External elastic pin of the yoke	1	Lega di acciaio Steel alloy
23	Spina elastica interna Internal elastic pin of the yoke	1	Lega di acciaio Steel alloy
24	Anello di centraggio Centering ring (OPTIONAL)	1	Lega di alluminio Aluminium alloy
25	Vite di regolazione corsa Stroke adjustment screw	2	Acciaio inox Stainless steel

* Particolari del kit di ricambio Components of spare part kit



COMPONENTI DOPPIO EFFETTO: GD 2880
DOUBLE ACTING COMPONENTS: GD 2880

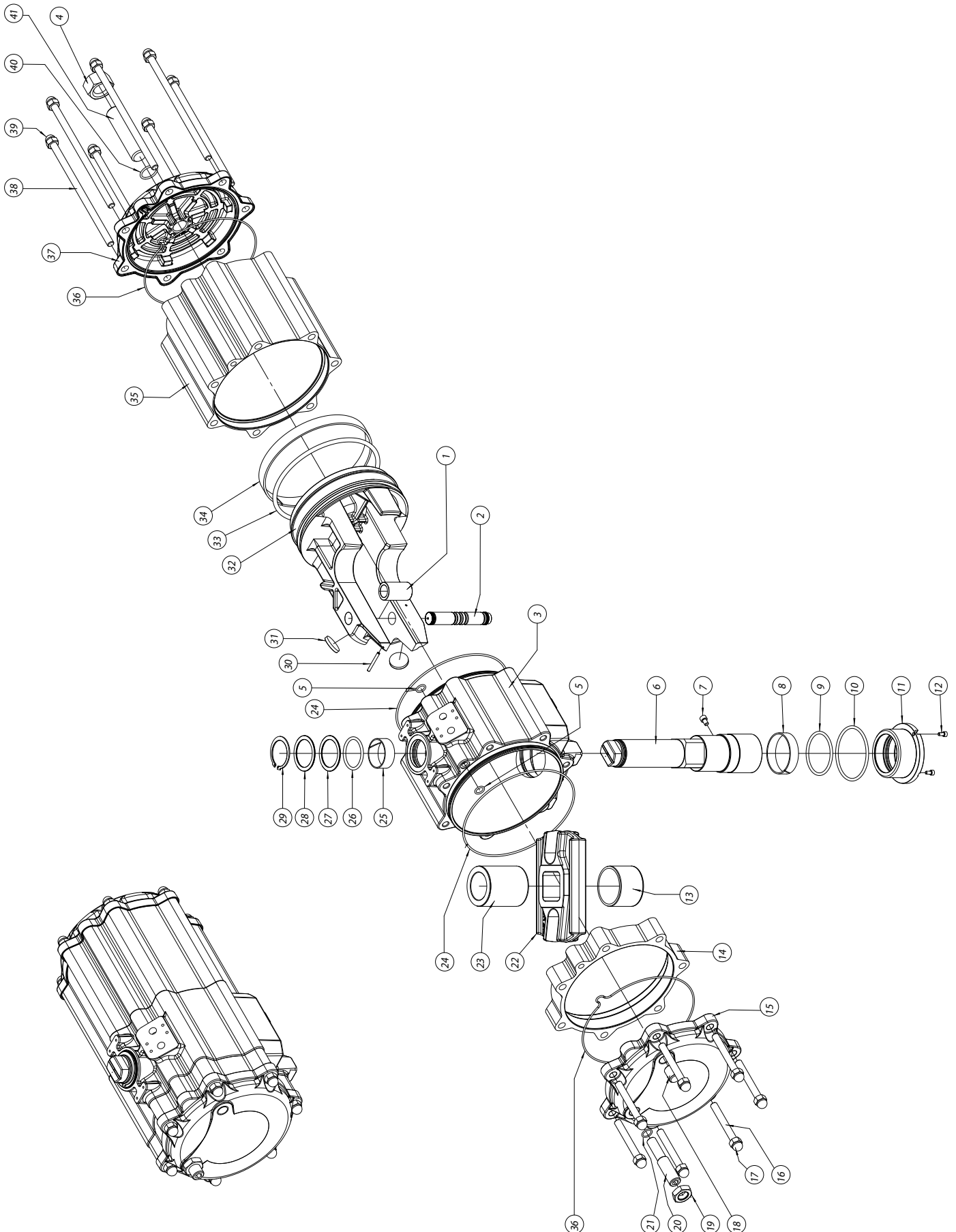



MATERIALI MATERIALS				
Pos	Denominazione	Q.ty	Denominazione	Materiale
22	Forcella Scotch yoke	1		Acciaio Steel alloy
23	Bussola di scorr/supp Bearing shaft	1		Resina acetaltica Acetalic resin
24*	O-ring	2		Gomma nitrilica Nitrilic rubber
25*	Supporto superiore Bearing (shaft top)	1		P.T.F.E. carbo-graphite filled
26*	O-ring	1		FKM
27*	Anello di supporto esterno Thrust bearing	1		Resina acetaltica Acetalic resin
28	Rondella di spessoramento Washer	1		Acciaio Steel alloy
29	Seeger	1		Acciaio Steel alloy
30	Spina antiespulsione Spring pin	1		Acciaio Steel alloy
31*	Dischetti Bearing (piston back)	2		Resina acetaltica Acetalic resin
32	Pistone Piston	1		Alluminio Aluminium
33*	O-ring	1		Gomma nitrilica Nitrilic rubber
34*	Anello di guida Bearing (piston head)	1		P.T.F.E. Carbo-Graphite filled
35	Cilindro laterale Lateral cylinder	1		Alluminio Aluminium
36*	O-ring	2		Gomma nitrilica Nitrilic rubber
37	Tappo Cap	1		Alluminio Aluminium
38	Vite di assemblaggio Cap screw	7		Acciaio Steel alloy
39	Dado a calotta Cap nut	7		Acciaio Steel alloy
40*	O-ring	1		Gomma nitrilica Nitrilic rubber
41	Grano di regolazione Grub screw	1		Acciaio Steel alloy

* Particolari del kit di ricambio Components of spare part kit

MATERIALI MATERIALS				
Pos	Denominazione	Q.ty	Denominazione	Materiale
1	Bussola acciaio Steel bush	1		Acciaio Steel alloy
2	Spina acciaio Steel pin	1		Acciaio Steel alloy
3	Corpo Body	1		Alluminio Aluminium
4	Dado Nut	1		Acciaio Steel alloy
5*	O-ring	2		Gomma nitrilica Nitrilic rubber
6	Albero Shaft	1		Acciaio Steel alloy
7	Vite antiespulsione Screw	1		Acciaio Steel alloy
8*	Supporto inferiore Bearing (shaft bottom)	1		P.T.F.E. carbo-graphite filled
9*	O-ring	1		FKM
10*	O-ring	1		FKM
11	Bussola di supporto inferiore Low bearing bush	1		Alluminio Aluminium
12	Vite per bussola Screw	2		Acciaio Steel alloy
13	Bussola di scorrimento Bearing shaft	1		Resina acetaltica Acetalic resin
14	Distanziale Spacer	1		Alluminio Aluminium
15	Tappo Cap	1		Alluminio Aluminium
16	Vite di assemblaggio Cap screw	7		Acciaio Steel alloy
17	Dado a calotta Cap nut	7		Acciaio Steel alloy
18	Grano (Tappo) Grub screw	1		Acciaio Steel alloy
19	Dado Nut	1		Acciaio Steel alloy
20	Grano di regolazione Grub screw	1		Acciaio Steel alloy
21*	O-ring	1		Gomma nitrilica Nitrilic rubber

* Particolari del kit di ricambio Components of spare part kit



COMPONENTI DOPPIO EFFETTO: **GD 3840**

DOUBLE ACTING COMPONENTS: **GD 3840**

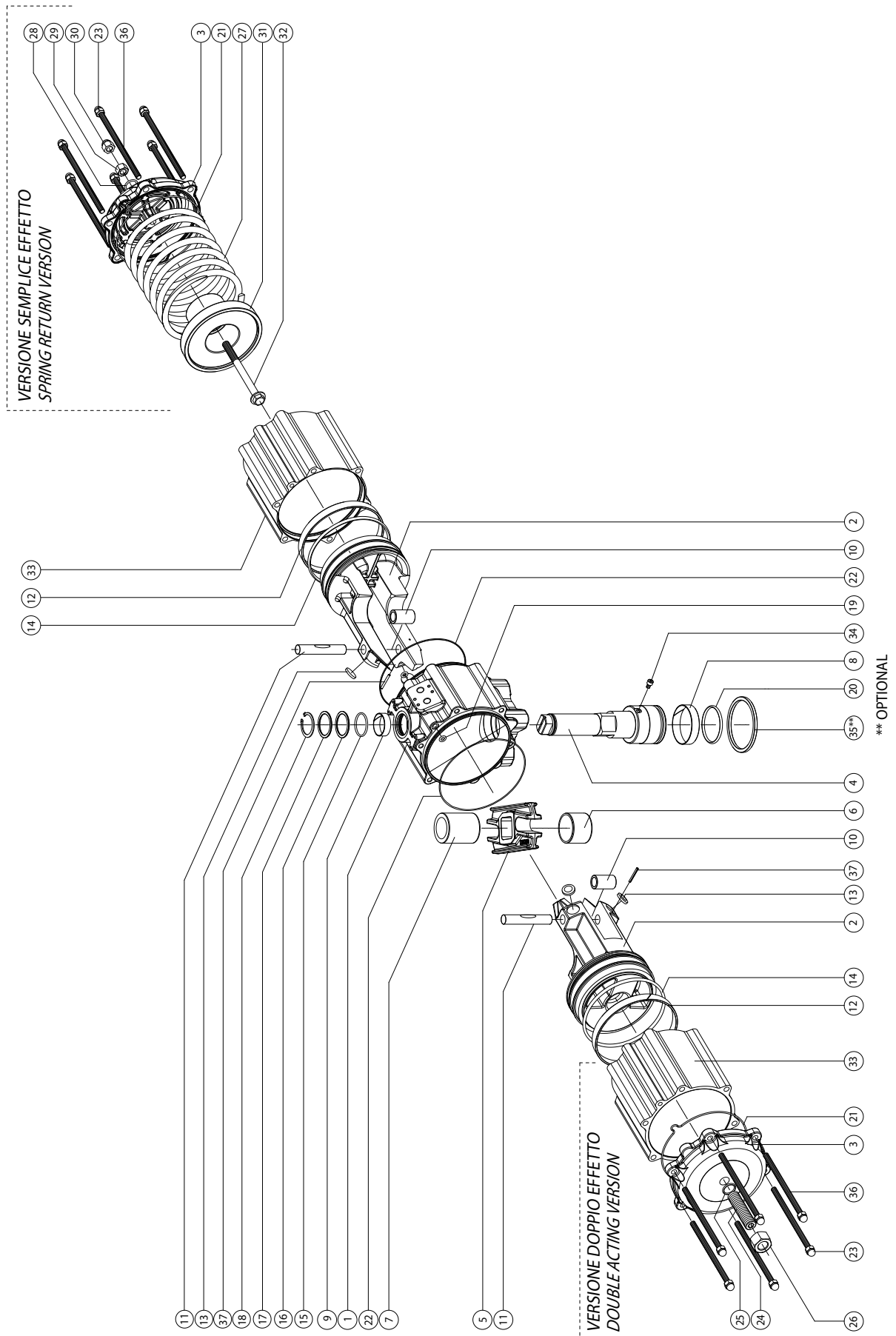



MATERIALI MATERIALS			
Pos	Denominazione Denomination	Q.ty	Materiale Material
20*	O-ring albero inferiore O-ring	1	FKM
21*	O-ring tappo O-ring	2	Gomma nitrilica Nitrilic rubber
22*	O-ring corpo-cilindro O-ring	2	Gomma nitrilica Nitrilic rubber
23	Dado a calotta Cap nut	12	Acciaio inox Stainless steel
24	Grano di regolaz. Grub screws	2	Acciaio inox Stainless steel
25*	O-ring grano O-ring	2	Gomma nitrilica Nitrilic rubber
26	Dado Nut	2	Acciaio inox Stainless steel
27	Molla Spring	4	Leghe di acciaio Steel alloy
28*	O-ring regolazione O-ring	2	Gomma nitrilica Nitrilic rubber
29	Dado Nut	2	Acciaio inox Stainless steel
30	Dado a calotta Cap nut	2	Acciaio inox Stainless steel
31	Contentitore a molla Spring cap	2	Leghe di alluminio Aluminium alloy
32	Vite di prec.molla Screw	2	Acciaio inox Stainless steel
33	Cilindro laterale Cylinder	2	Leghe di alluminio Aluminium alloy
34	Vite antiespulsione Screw	1	Acciaio inox Stainless steel
35**	Anello di centraggio Center ring (OPTIONAL)	1	Leghe di alluminio Aluminium alloy
36	Vite di assemblaggio Cap screw	12	Acciaio Steel alloy
37	Spina antiespulsione Spring pin	2	Leghe di acciaio Steel alloy

* Particolari del kit di ricambio Components of spare part kit

** Optional

MATERIALI MATERIALS			
Pos	Denominazione Denomination	Q.ty	Materiale Material
1	Cilindro Cylinder	1	Leghe di alluminio Aluminium alloy
2	Pistone Piston	2	Leghe di alluminio Aluminium alloy
3	Tappo Cap	2	Leghe di alluminio Aluminium alloy
4	Albero Shaft	1	Acciaio inox Stainless steel
5	Forcella Scotch yoke	1	Leghe di acciaio Steel alloy
6	Bussola di scorrimento Bearing shaft	1	Resina acetica Acetalic resins
7	Bussola scorrim/supporto Bearing shaft	1	Resina acetica Acetalic resins
8*	Fascetta supp.infer. Bearing (shaft bottom)	1	PT.F.E. carbo-graphite filled
9*	Fascetta supp.super. Bearing (shaft top)	1	PT.F.E. carbo-graphite filled
10	Bussola acciaio Steel bush	2	Leghe di acciaio Steel alloy
11	Spina acciaio Steel pin	2	Leghe di acciaio Steel alloy
12*	Anello di guida Bearing (piston head)	2	PT.F.E. Carbo-Graphite filled
13*	Dischetto supporto Bearing (piston back)	4	Resina acetica Acetalic resins
14*	O-ring del pistone O-ring	2	Gomma nitrilica Nitrilic rubber
15*	O-ring albero sup. O-ring	1	FKM
16*	Anello supporto est. Thrust bearing	1	Resina acetica Acetalic resins
17	Rondella spessoramento Washer	1	Acciaio inox Stainless steel
18	Seeger	1	Acciaio inox Stainless steel
19*	O-ring cond.aria O-ring	2	Gomma nitrilica Nitrilic rubber

* Particolari del kit di ricambio Components of spare part kit



COMPONENTI DOPPIO EFFETTO: GD 5760
DOUBLE ACTING COMPONENTS: GD 5760

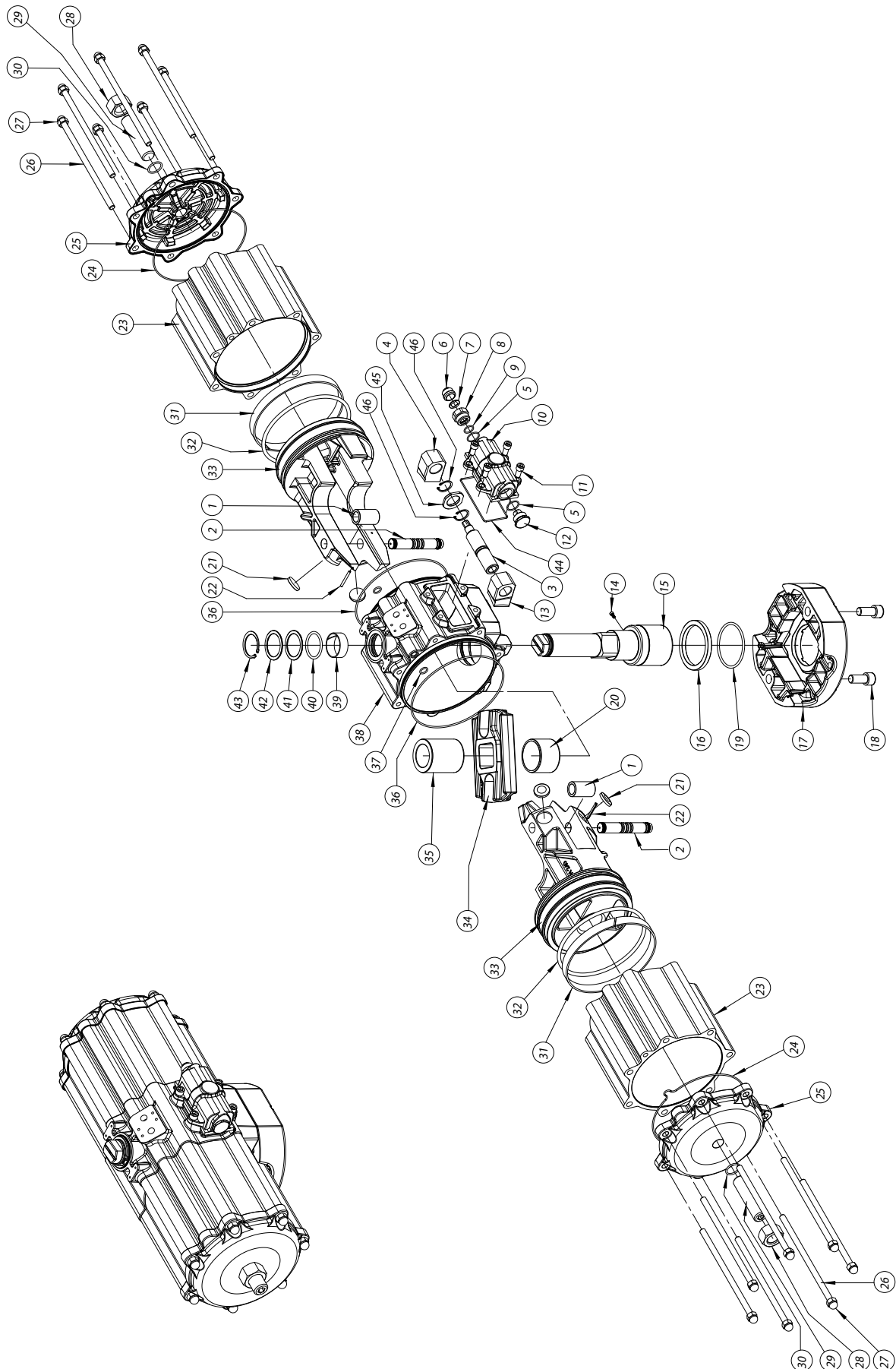



MATERIALI MATERIALS			
Pos	Denominazione	Q.ty	Materiale Material
1	Bussola acciaio Steel bush	2	Acciaio Steel alloy
2	Spina acciaio Steel pin	2	Acciaio Steel alloy
3	Vite di regolazione Regulation screw	1	Acciaio Steel alloy
4	Fermo sinistro Left stop	1	Acciaio Steel alloy
5*	O-ring	2	Gomma nitrilica Nitrilic rubber
6	Tappo di protezione Protection cap	1	Alluminio Aluminium
7	Rondella antirrotazione Antirotation washer	1	Acciaio Steel alloy
8	Ghiera passante Metal ring	1	Acciaio inox Stainless steel
9*	O-ring	1	Gomma nitrilica Nitrilic rubber
10	Carter di regolaz. Carter	1	Alluminio Aluminium
11	Vite per carter Screw	4	Acciaio Steel alloy
12	Ghiera cieca Metal ring	1	Acciaio inox Stainless steel
13	Fermo destro Right stop	1	Acciaio Steel alloy
14	Vite antiespulsione Screw	1	Acciaio Steel alloy
15	Albero Shaft	1	Acciaio Steel alloy
16	Supporto inferiore Bearing (shaft bottom)	1	P.T.F.E. carbo-graphite filled
17	Interfaccia F25 Interface F25	1	Alluminio Aluminium
18	Vite per interfaccia Screw	2	Acciaio Steel alloy
19*	O-ring	1	FKM
20	Bussola di scorrimento Bearing shaft	1	Resina acetaltica Acetalic resins
21*	Dischetti Bearing (piston back)	4	Resina acetaltica Acetalic resins
22	Spina antiespulsione Spring pin	2	Acciaio Steel alloy
23	Cilindro laterale Lateral cylinder	2	Alluminio Aluminium

* Particolari del kit di ricambio Components of spare part kit

MATERIALI MATERIALS			
Pos	Denominazione	Q.ty	Materiale Material
24*	O-ring tappo O-ring	2	Gomma nitrilica Nitrilic rubber
25	Tappo Cap	2	Alluminio Aluminium
26	Vite di assemblaggio Cap screws	14	Acciaio Steel alloy
27	Dado a calotta Cap nut	14	Acciaio Steel alloy
28	Dado Nut	2	Acciaio Steel alloy
29	Grano di regolazione Grub screws	2	Acciaio Steel alloy
30*	O-ring	2	Gomma nitrilica Nitrilic rubber
31*	Anello di guida Bearing (piston head)	2	P.T.F.E. Carbo-Graphite filled
32*	O-ring pistone O-ring	2	Gomma nitrilica Nitrilic rubber
33	Pistone Piston	2	Alluminio Aluminium
34	Forcella Scotch yoke	1	Acciaio Steel alloy
35	Bussola di scorr./supp Bearing shaft	1	Resina acetaltica Acetalic resin
36*	O-ring	2	Gomma nitrilica Nitrilic rubber
37*	O-ring	2	Gomma nitrilica Nitrilic rubber
38	Corpo Body	1	Alluminio Aluminium
39*	Supporto superiore Bearing (shaft top)	1	P.T.F.E. carbo-graphite filled
40*	O-ring	1	FKM
41*	Anello di supp. esterno Thrust bearing	1	Resina acetaltica Acetalic resin
42	Rondella di spessoram. Washer	1	Acciaio Steel alloy
43	Seeger	1	Acciaio Steel alloy
44*	Guarnizione carter Gasket	1	Gomma nitrilica Nitrilic rubber
45	Rondella di supporto Washer	1	Acciaio Steel alloy
46	Seeger	2	Acciaio Steel alloy

* Particolari del kit di ricambio Components of spare part kit



COMPONENTI DOPPIO EFFETTO: GD 8000
DOUBLE ACTING COMPONENTS: GD 8000

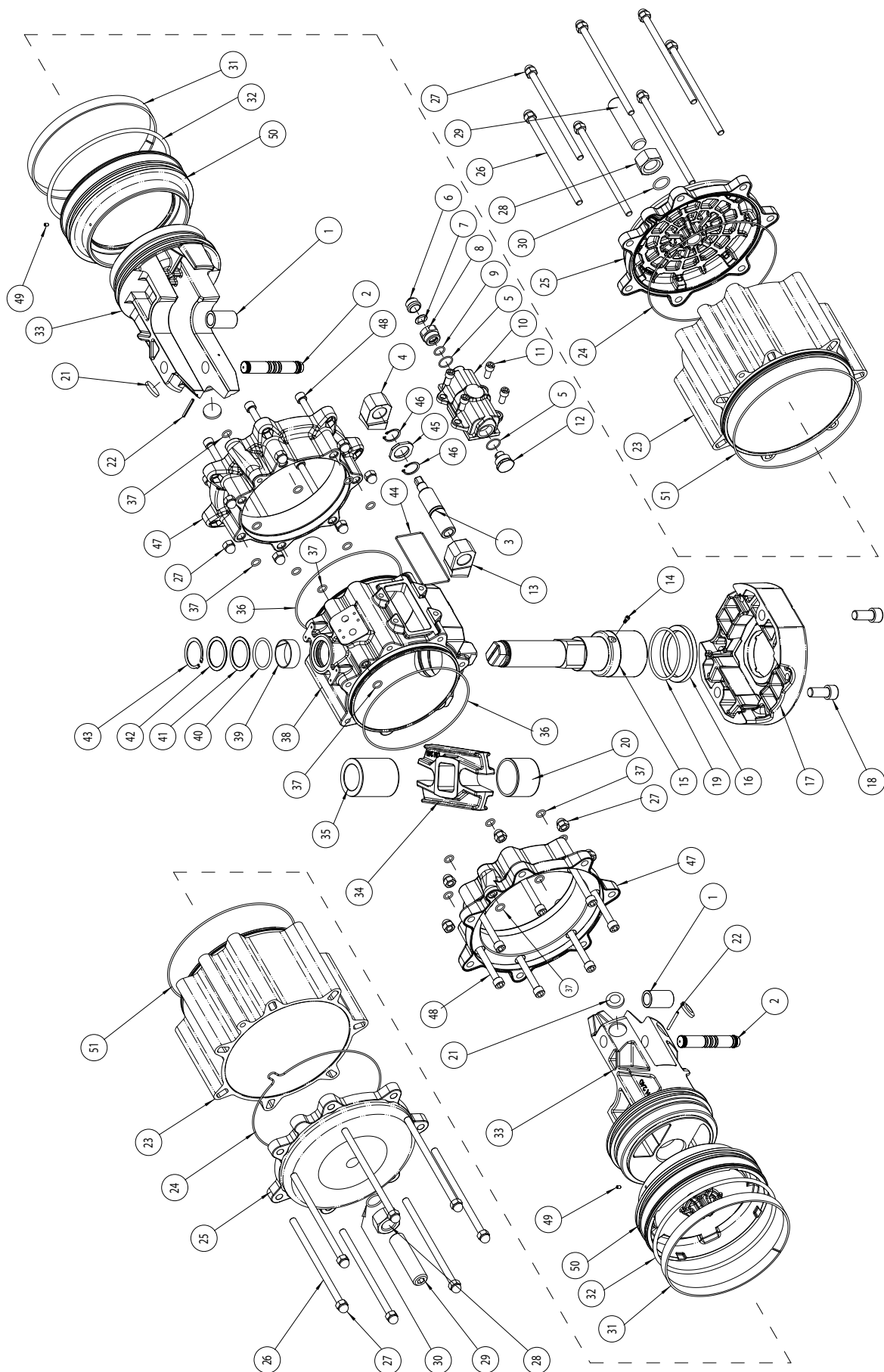



MATERIALI MATERIALS			
Pos	Denominazione Denomination	Q.ty	Materiale Material
27	Dado a calotta Cap nut	28	Acciaio Steel alloy
28	Dado Nut	2	Acciaio Steel alloy
29	Grano di regolazione Grub screws	2	Acciaio Steel alloy
30*	O-ring	2	Gomma nitrilica Nitrilic rubber
31*	Anello di guida Bearing (piston head)	2	PT.FE. Carbo-Graphite filled
32*	O-ring pistone O-ring	2	Gomma nitrilica Nitrilic rubber
33	Pistone Piston	2	Alluminio Aluminium
34	Forcella Scotch yoke	1	Acciaio Steel alloy
35	Bussola di scorr/supp Bearing shaft	1	Resina acetatica Acetalic resins
36*	O-ring	2	Gomma nitrilica Nitrilic rubber
37*	O-ring	18	Gomma nitrilica Nitrilic rubber
38	Corpo Body	1	Alluminio Aluminium
39*	Supporto superiore Bearing (shaft top)	1	PT.FE. carbo-graphite filled
40*	O-ring	1	FKM
41*	Anello di suppe.sterno Thrust bearing	1	Resina acetatica Acetalic resins
42	Rondella di spessore Washer	1	Acciaio Steel alloy
43	Seeger	1	Acciaio Steel alloy
44*	Guarnizione carter Gasket	1	Gomma nitrilica Nitrilic rubber
45	Rondella supporto Washer	1	Acciaio Steel alloy
46	Seeger	2	Acciaio Steel alloy
47	Flangia rid.cilindro Flange	2	Alluminio Aluminium
48	Viti flangia Screws	14	Acciaio Steel alloy
49	Grano Grub screw	2	Acciaio Steel alloy
50	Flangia rid.pistone Flange	2	Alluminio Aluminium
51*	O-ring	2	Gomma nitrilica Nitrilic rubber

* Particolari del kit di ricambio Components of spare part kit

MATERIALI MATERIALS			
Pos	Denominazione Denomination	Q.ty	Materiale Material
1	Bussola acciaio Steel bush	2	Acciaio Steel alloy
2	Spina acciaio Steel pin	2	Acciaio Steel alloy
3	Vite di regolazione Regulation screw	1	Acciaio Steel alloy
4	Fermo sinistro Left stop	1	Acciaio Steel alloy
5*	O-ring	2	Gomma nitrilica Nitrilic rubber
6	Tappo di protezione Protection cap	1	Alluminio Aluminium
7	Rondella antirotazione Antirotation washer	1	Acciaio Steel alloy
8	Ghiera passante Metal ring	1	Acciaio inox Stainless steel
9*	O-ring	1	Gomma nitrilica Nitrilic rubber
10	Carter di regolaz. Carter	1	Alluminio Aluminium
11	Vite per carter Screw	4	Acciaio Steel alloy
12	Ghiera cieca Metal ring	1	Acciaio inox Stainless steel
13	Fermo destro Right stop	1	Acciaio Steel alloy
14	Vite antiespulsione Screw	1	Acciaio Steel alloy
15	Albero Shaft	1	Acciaio Steel alloy
16	Supporto inferiore Bearing (shaft bottom)	1	PT.FE. carbo-graphite filled
17	Interfaccia F25 Interface F25	1	Alluminio Aluminium
18	Vite per interfaccia Screw	2	Acciaio Steel alloy
19*	O-ring	1	FKM
20	Bussola di scorrimento Bearing shaft	1	Resina acetatica Acetalic resins
21*	Dischetti Bearing (piston back)	4	Resina acetatica Acetalic resins
22	Spina antiespulsione Spring pin	2	Acciaio Steel alloy
23	Cilindro laterale Lateral cylinder	2	Alluminio Aluminium
24*	O-ring tappo O-ring	2	Gomma nitrilica Nitrilic rubber
25	Tappo Cap	2	Alluminio Aluminium
26	Vite di assemblaggio Cap screws	14	Acciaio Steel alloy

* Particolari del kit di ricambio Components of spare part kit



ATTUATORE PNEUMATICO SEMPLICE EFFETTO "GS" IN ALLUMINIO

ALUMINIUM SPRING RETURN PNEUMATIC ACTUATOR "GS" TYPE



DATI TECNICI

- Coppia da 15 Nm a 4000 Nm.
- Flangia d'attacco: EN ISO 5211
F03 - F04 - F05 - F07 - F10 - F12 - F14 - F16 - F25.
- Conforme alla EN 15714-3.
- Angolo di rotazione: 92° (-1°, +91°).
- Momento torcente: Il momento torcente di ritorno dipende solo dall'azione della molla ed è indipendente dalla pressione di alimentazione. Sono disponibili 4 differenti tarature per la molla; vedi tabella.
- La chiusura automatica per mezzo delle molle avviene in senso orario. Nel codice degli attuatori GS versione standard è indicata la taglia delle molle (6=5,6 bar) seguita dalla coppia di spunto in Nm alla pressione di 5,6 bar.
- **ATEX in conformità alla direttiva 2014/34/UE.**

CONDIZIONI DI ESERCIZIO

- Temperatura: da -20°C a +80°C. (Versioni speciali: alta temperatura: -20°C +150°C; bassa temperatura: -50°C +60°C).
- Pressione nominale: 5,6 bar; massima di esercizio 8,4 bar.
- Fluido di alimentazione: aria compressa filtrata secca non necessariamente lubrificata.
- In caso di lubrificazione usare olio non detergente, compatibile con NBR.

TECHNICAL FEATURES

- Torque from 15 Nm to 4000 Nm.
- Mounting flange according to EN ISO 5211
F03 - F04 - F05 - F07 - F10 - F12 - F14 - F16 - F25.
- In compliance with EN 15714-3.
- Rotation angle: 92° (-1°, +91°).
- Torque: the return torque depends on spring action only notwithstanding the air supply. The spring is provided in four different sizes (see table).
- The actuator automatic closing takes place in clockwise direction by means of its springs.
In the code of standard version GS actuators, it is indicated the size of the springs (6=5,6 bar) followed by the breakaway torque in Nm at 5,6 bar air supply.
- **ATEX version in conformity with directive 2014/34/EU.**

WORKING CONDITION

- Temperature: from -20°C to +80°C. (Special versions: high temperature: -20°C +150°C; low temperature: -50°C +60°).
- Air supply: 5,6 bar; maximum 8,4 bar.
- Actuating media: filtered dry compressed air, not necessarily lubricated.
- In case of lubricated air, either non detergent oil, NBR compatible oil, must be used.



DIAGRAMMA DEL MOMENTO TORCENTE IN FUNZIONE DELL'ANGOLO DI ROTAZIONE
OUTPUT TORQUE DIAGRAM RELATED TO ROTATION ANGLE



TABELLA DEL MOMENTI TORCENTI (Nm) OUTPUT TORQUE TABLE (Nm)		$\alpha^\circ =$ ANGOLO DI ROTAZIONE $\alpha^\circ =$ ROTATION ANGLE							
MISURA SIZE	α°	2,8 bar ÷ 40 PSI		3,5 bar ÷ 50 PSI		4,2 bar ÷ 60 PSI		5,6 bar ÷ 80 PSI	
		aria air	molla spring	aria air	molla spring	aria air	molla spring	aria air	molla spring
GS 15	0°	7,5	5	9,4	6,3	11,3	7,5	15	10
	50°	3,7	3,7	4,7	4,7	5,6	5,6	7,5	7,5
	90°	5	7,5	6,3	9,4	7,5	11,3	10	15
GS 30	0°	15	10	18,8	12,5	22,5	15	30	20
	50°	7,5	7,5	9,4	9,4	11,3	11,3	15	15
	90°	10	15	12,5	18,8	15	22,5	20	30
GS 53	0°	26,5	17,5	33	22	40	26	53	35
	50°	13	13	16,5	16,5	19,5	19,5	26	26
	90°	17,5	26,5	22	33	26	40	35	53
GS 60	0°	30	20	37,5	25	45	30	60	40
	50°	15	15	18,8	18,8	22,5	22,5	30	30
	90°	20	30	25	37,5	30	45	40	60
GS 90	0°	45	30	56,3	37,5	67,5	45	90	60
	50°	22,5	22,5	28,1	28,1	33,9	33,9	45	45
	90°	30	45	37,5	56,3	45	67,5	60	90
GS 120	0°	60	40	75	50	90	60	120	80
	50°	30	30	37,5	37,5	45	45	60	60
	90°	40	60	50	75	60	90	80	120
GS 180	0°	90	60	112,5	75	135	90	180	120
	50°	45	45	56,3	56,3	67,5	67,5	90	90
	90°	60	90	75	112,5	90	135	120	180
GS 240	0°	120	80	150	100	180	120	240	160
	50°	60	60	75	75	90	90	120	120
	90°	80	120	100	150	120	180	160	240
GS 360	0°	180	120	225	150	270	180	360	240
	50°	90	90	112,5	112,5	135	135	180	180
	90°	120	180	150	225	180	270	240	360
GS 480	0°	240	160	300	200	360	240	480	320
	50°	120	120	150	150	180	180	240	240
	90°	160	240	200	300	240	360	320	480
GS 720	0°	360	240	450	300	540	360	720	480
	50°	180	180	225	225	270	270	360	360
	90°	240	360	300	450	360	540	480	720
GS 960	0°	480	320	600	400	720	480	960	640
	50°	240	240	300	300	360	360	480	480
	90°	320	480	400	600	480	720	640	960
GS 1440	0°	---	---	900	600	---	---	1440	960
	50°	---	---	450	450	---	---	720	720
	90°	---	---	600	900	---	---	960	1440
GS 1920	0°	960	640	1200	800	1440	960	1920	1280
	50°	480	480	600	600	720	720	960	960
	90°	640	960	800	1200	960	1440	1280	1920
GS 2880	0°	1440	960	1800	1200	2160	1440	2880	1920
	50°	720	720	900	900	1080	1080	1440	1440
	90°	960	1440	1200	1800	1440	2160	1920	2880
GS 4000	0°	2000	1333	2500	1666,3	3000	1999,5	4000	2666
	50°	1000	1000	1250	1250	1500	1500	2000	2000
	90°	1333	2000	1666,3	2500	1999,5	3000	2666	4000



Semplice effetto: **GS 15 (Nm) ÷ GS 53 (Nm)** Spring return: **GS 15 (Nm) ÷ GS 53 (Nm)**

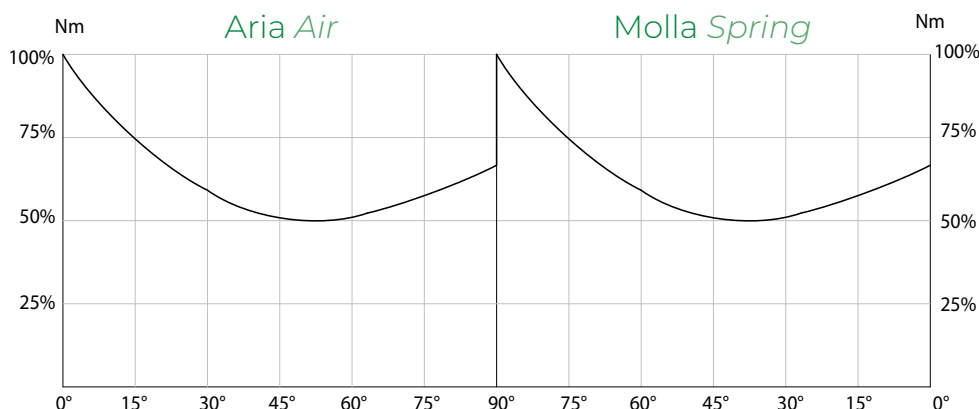
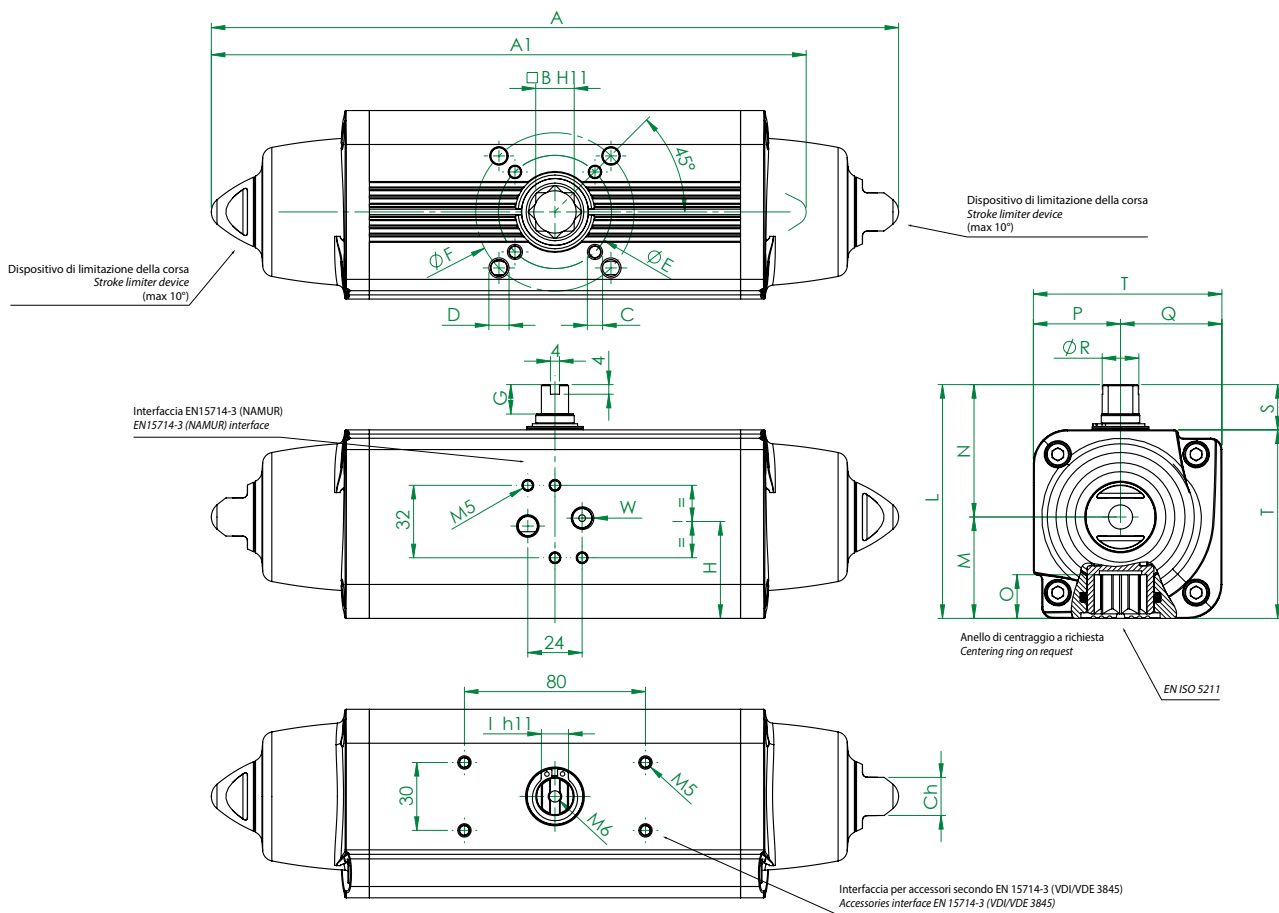

SCHEDA TECNICA DATA SHEET					
Codice Code	GS600150311S	GS600150411S	GS600300414S	GS600300514S	GS600530517S
Spare seals	KGGI0014		KGGI0016		KGGI0060
Misura Size	GS 15		GS 30		GS 53
ISO	F03/F05	F04	F04	F05/F07	F05/F07
A	233,3	233,3	259	259	304,3
A1 (2,8 Bar)	203,8	203,8	228,5	228,5	270,7
B	11	11	14	14	17
C x depth	M5x8	M5x8	M5x8	M6x9	M6x9
D x depth	M6x9	-	-	M8x12	M8x12
E	36	42	42	50	50
F	50	-	-	70	70
G	10	10	13	13	13
H	30,3	30,3	35,7	35,7	42,8
I	9	9	10	10	12
L	79,2	79,2	90,4	90,4	103,3
M	31,5	31,5	37,7	37,7	44,8
N	47,7	47,7	52,7	52,7	58,5
O	13,2	13,2	16,5	16,5	19,3
P	27,7	27,7	32,7	32,7	38,5
Q	31,5	31,5	37,7	37,7	44,8
R	10,9	10,9	14,5	14,5	16,2
S	20	20	20	20	20
T	59,2	59,2	70,4	70,4	83,3
W (Gas)	1/8"	1/8"	1/8"	1/8"	1/8"
Ch	13	13	13	13	17
Weight (Kg)	1,2	1,2	1,95	1,95	3
Air (dm ³ /cycle)	0,09	0,09	0,16	0,16	0,29

H = CENTRO DEI FISSAGGI BASETTA H = CENTER OF PLATE'S FIXING



Semplice effetto: **GS 60 (Nm) ÷ GS 360 (Nm)** Spring return: **GS 60 (Nm) ÷ GS 360 (Nm)**

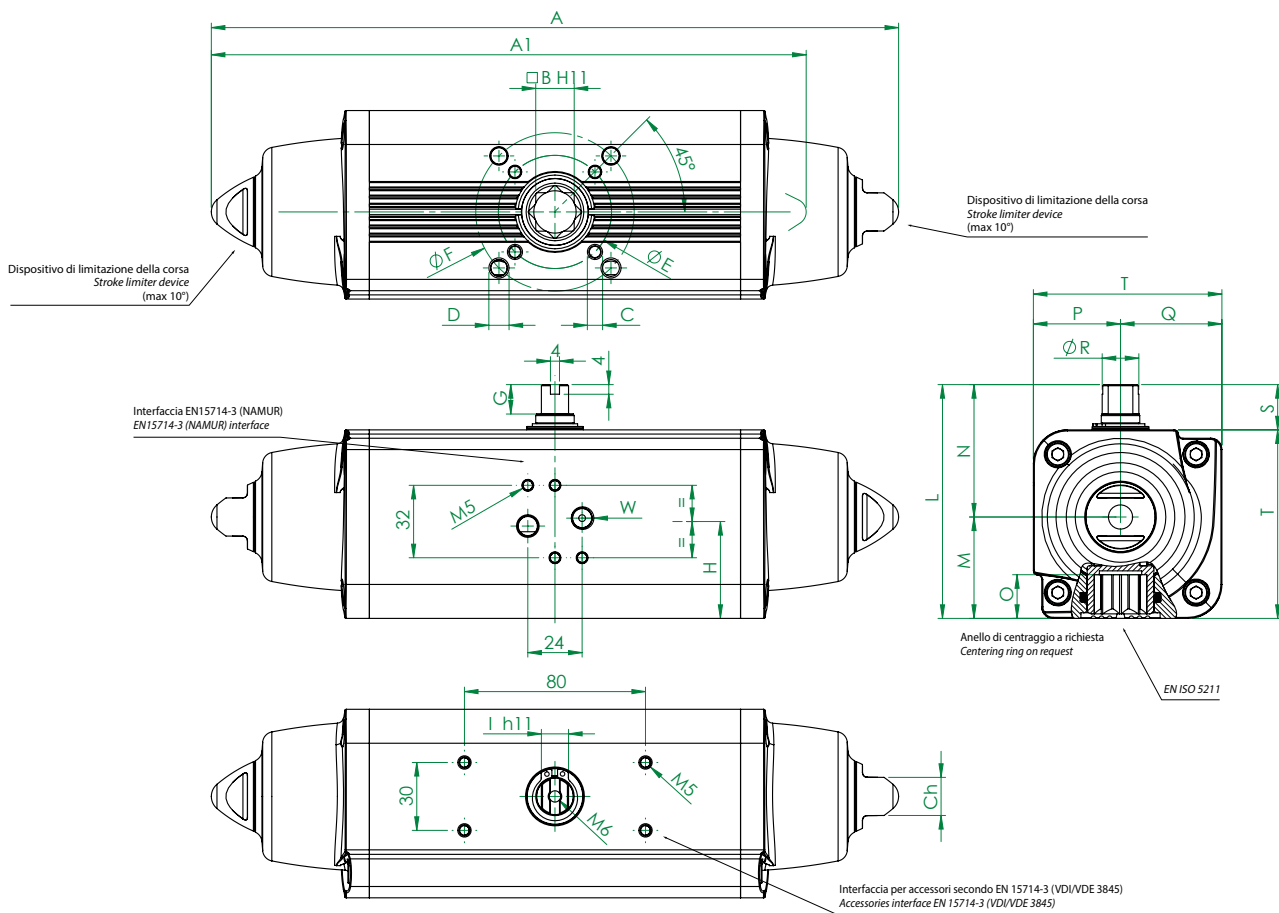

SCHEDA TECNICA DATA SHEET

Codice Code	GS600600517S	GS600900722S	GS601200722S	GS601800722S	GS602401027S	GS603601027S
Spare seals	KGGI0018	KGGI0019	KGGI0020	KGGI0021	KGGI0022	KGGI0023
Misura Size	GS 60	GS 90	GS 120	GS 180	GS 240	GS 360
ISO	F05/F07	F07/F10	F07/F10	F07/F10	F10/F12	F10/F12
A	338,5	393,7	409,6	474	520,5	613
A1 (2,8 Bar)	309,1	341,8	361,6	406,6	454,1	523
B	17	22	22	22	27	27
C x depth	M6x9	M8x12	M8x12	M8x12	M10x15	M10x15
D x depth	M8x12	M10x15	M10x15	M10x15	M12x18	M12x18
E	50	70	70	70	102	102
F	70	102	102	102	125	125
G	13	16	17	19	19	19,5
H	44,8	54,5	58,1	60	57,4	61,5
I	12	15	15	19	19	22
L	107	137,5	141,1	148	164,9	178
M	46,8	56,5	60,1	62	72,9	78,5
N	60,2	81	81	86	92	99,5
O	19,3	24,8	24,8	24,3	29,5	29,5
P	40,2	51	51	56	62	69,5
Q	46,8	56,5	60,1	62	72,9	78,5
R	18	20,2	22,5	25,5	29	31,8
S	20	30	30	30	30	30
T	87	107,5	111,1	118	134,9	148
W (Gas)	1/8"	1/8"	1/8"	1/8"	1/4"	1/4"
Ch	17	22	22	22	27	27
Weight (Kg)	3,35	5,9	6,8	8,9	11,8	16,5
Air (dm ³ /cycle)	0,33	0,51	0,68	1,01	1,32	2,04

H = CENTRO DEI FISSAGGI Basetta H = CENTER OF PLATE'S FIXING



Semplice effetto: **GS 480 (Nm) ÷ GS 960 (Nm)** Spring return: **GS 480 (Nm) ÷ GS 960 (Nm)**

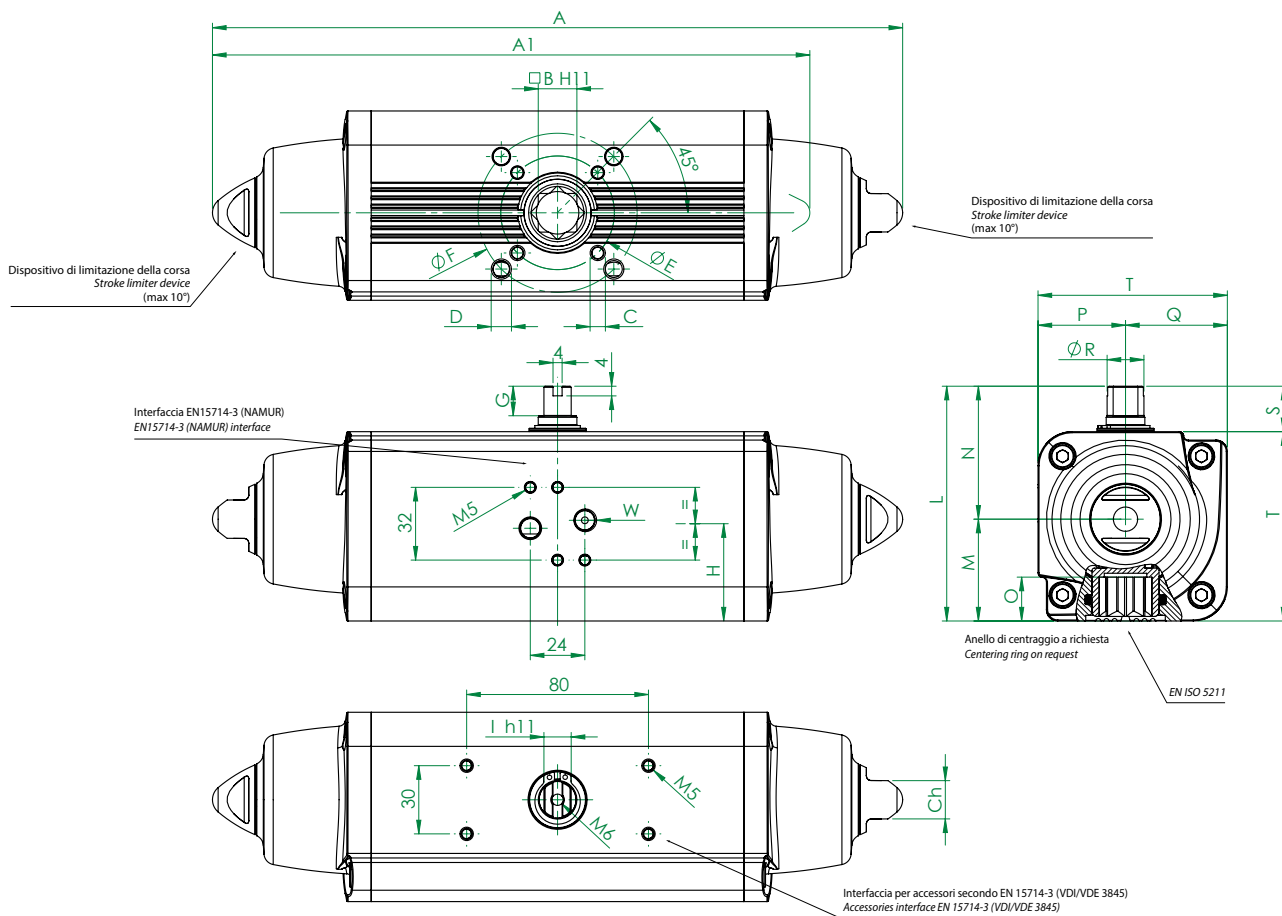

SCHEDA TECNICA DATA SHEET

Codice Code	GS604801236S	GS604801436S	GS607201236S	GS607201436S	GS609601646S	GS609601446S
Spare seals	KGGI0024		KGGI0025		KGGI0026	
Misura Size	GS 480		GS 720		GS 960	
ISO	F10/F12	F14	F12	F14	F12/F16	F14
A	648,2	648,2	798	798	828	828
A1 (2,8 Bar)	563,8	563,8	683	683	714,4	714,4
B	36	36	36	36	46	46
C x depth	M10x15	M16x24	M12x18	M16x24	M12x18	M16x24
D x depth	M12x18	-	-	-	M20x30	-
E	102	140	125	140	125	140
F	125	-	-	-	165	-
G	19,5	19,5	19,5	19,5	18,5	18,5
H	78	78	86,5	86,5	99,2	99,2
I	24	24	27	27	32	32
L	198	198	216	216	237,7	237,7
M	93,5	93,5	101,5	101,5	114,7	114,7
N	104,5	104,5	114,5	114,5	123	123
O	38,5	38,5	38,5	38,5	48,5	48,5
P	74,5	74,5	84,5	84,5	93	93
Q	93,5	93,5	101,5	101,5	114,7	114,7
R	36,5	36,5	41	41	46	46
S	30	30	30	30	30	30
T	168	168	186	186	207,7	207,7
W (Gas)	1/4"	1/4"	1/4"	1/4"	1/4"	1/4"
Ch	27	27	36	36	36	36
Weight (Kg)	22,7	22,7	33	33	42	42
Air (dm ³ /cycle)	2,62	2,62	4,25	4,25	5,57	5,57

H = CENTRO DEI FISSAGGI BASETTA H = CENTER OF PLATE'S FIXING



Semplice effetto: **GS 1440 (Nm)** Spring return: **GS 1440 (Nm)**

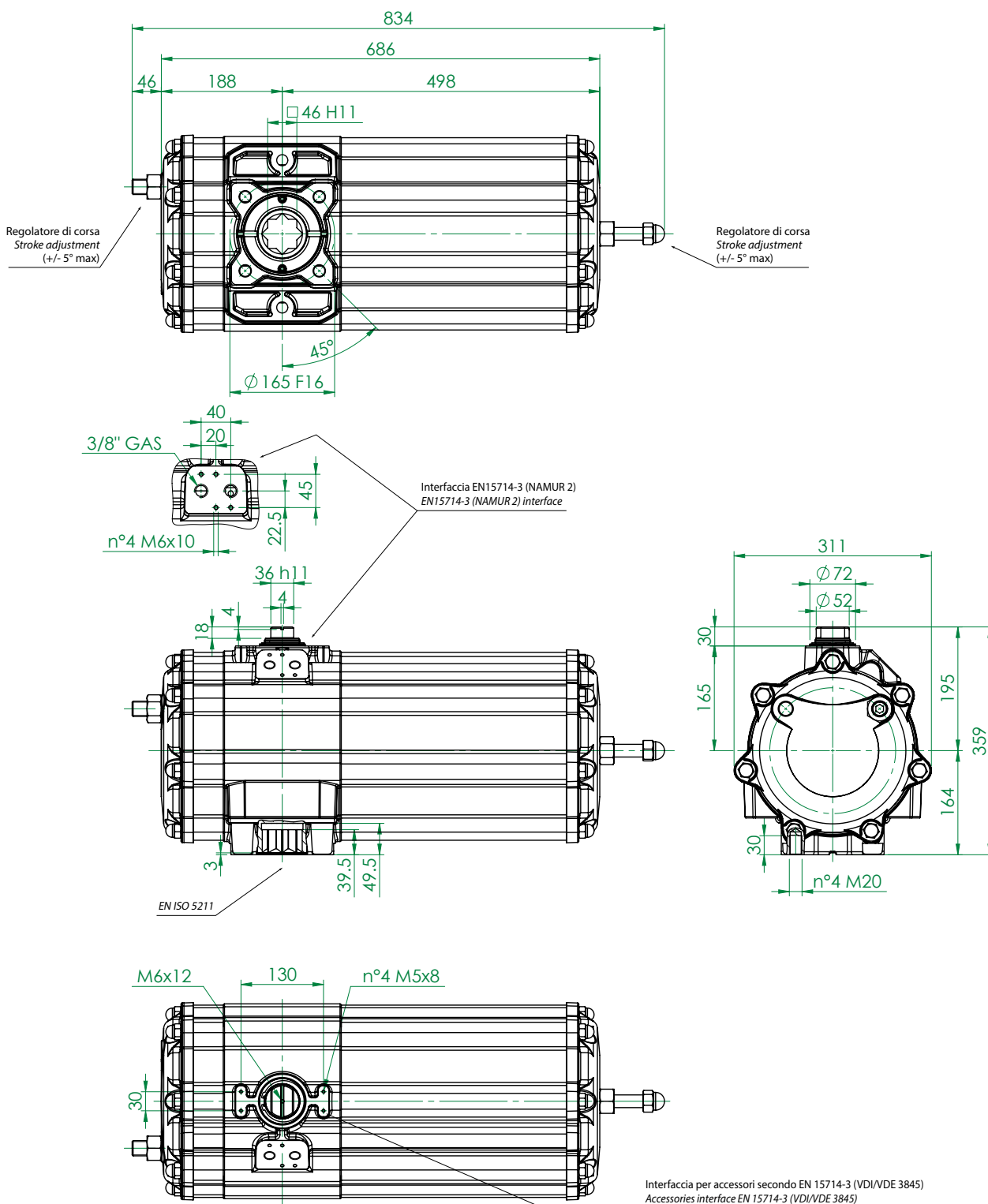

SCHEDA TECNICA DATA SHEET

Codice Code		GS614401646S
Peso Weight	Kg	74,0
Volume aria Air volume	dm ³ /cycle	16,79
Guarnizioni di ricambio Spare seals		KGSI1035



Semplice effetto: **GS 1920 (Nm)**

Spring return: **GS 1920 (Nm)**

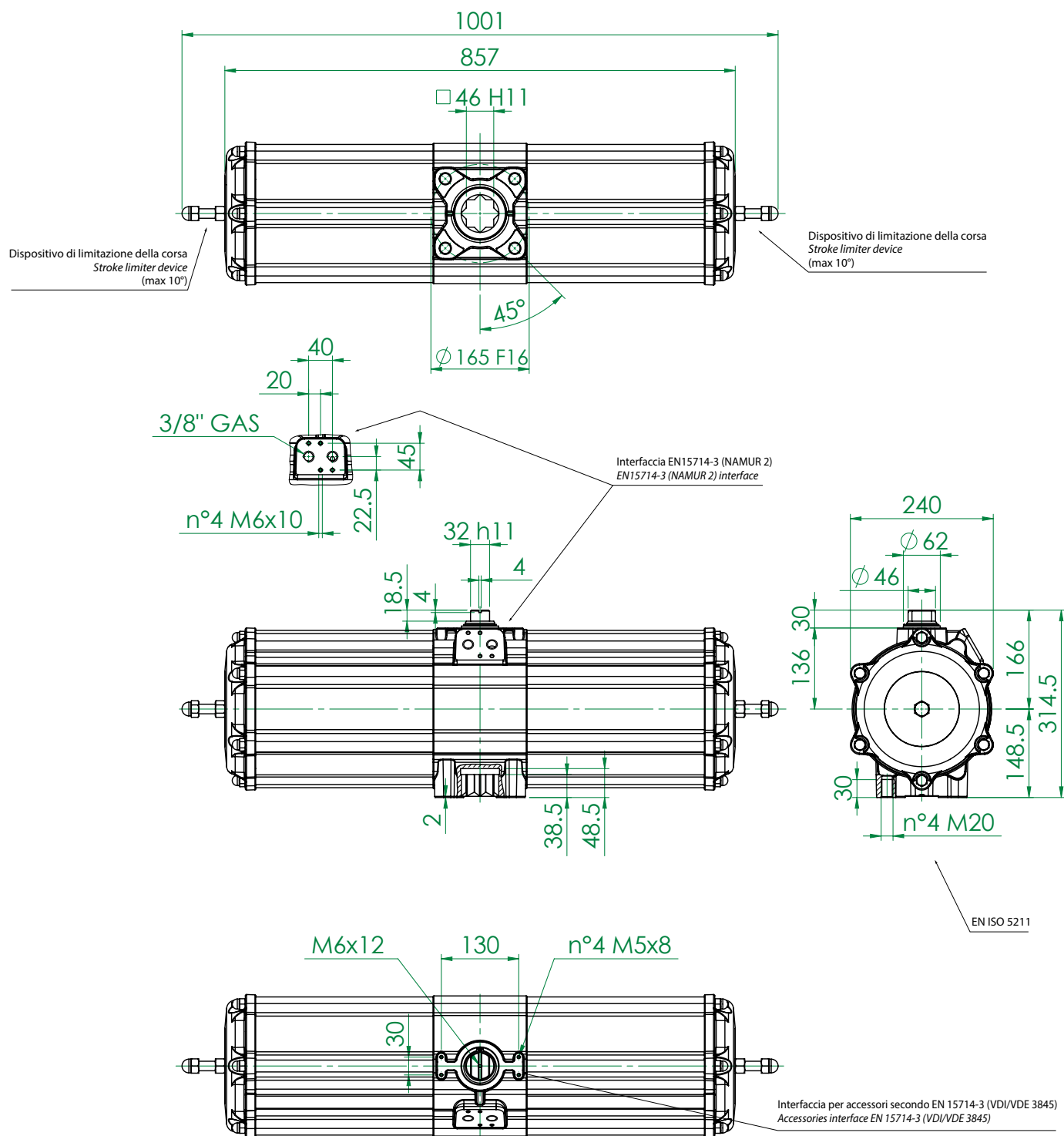

Disponibile versione con doppia regolazione della corsa (+/- 5°max) con codice GS6192016A04.
Available version with double stroke adjustment (+/- 5°max) with code GS6192016A04.

SCHEDA TECNICA		DATA SHEET
Codice Code		GS6192016465
Peso Weight	Kg	67,0
Volume aria Air volume	dm ³ /cycle	12,73
Guarnizioni di ricambio Spare seals		KGDI0030



Semplice effetto: **GS 2880 (Nm)** Spring return: **GS 2880 (Nm)**

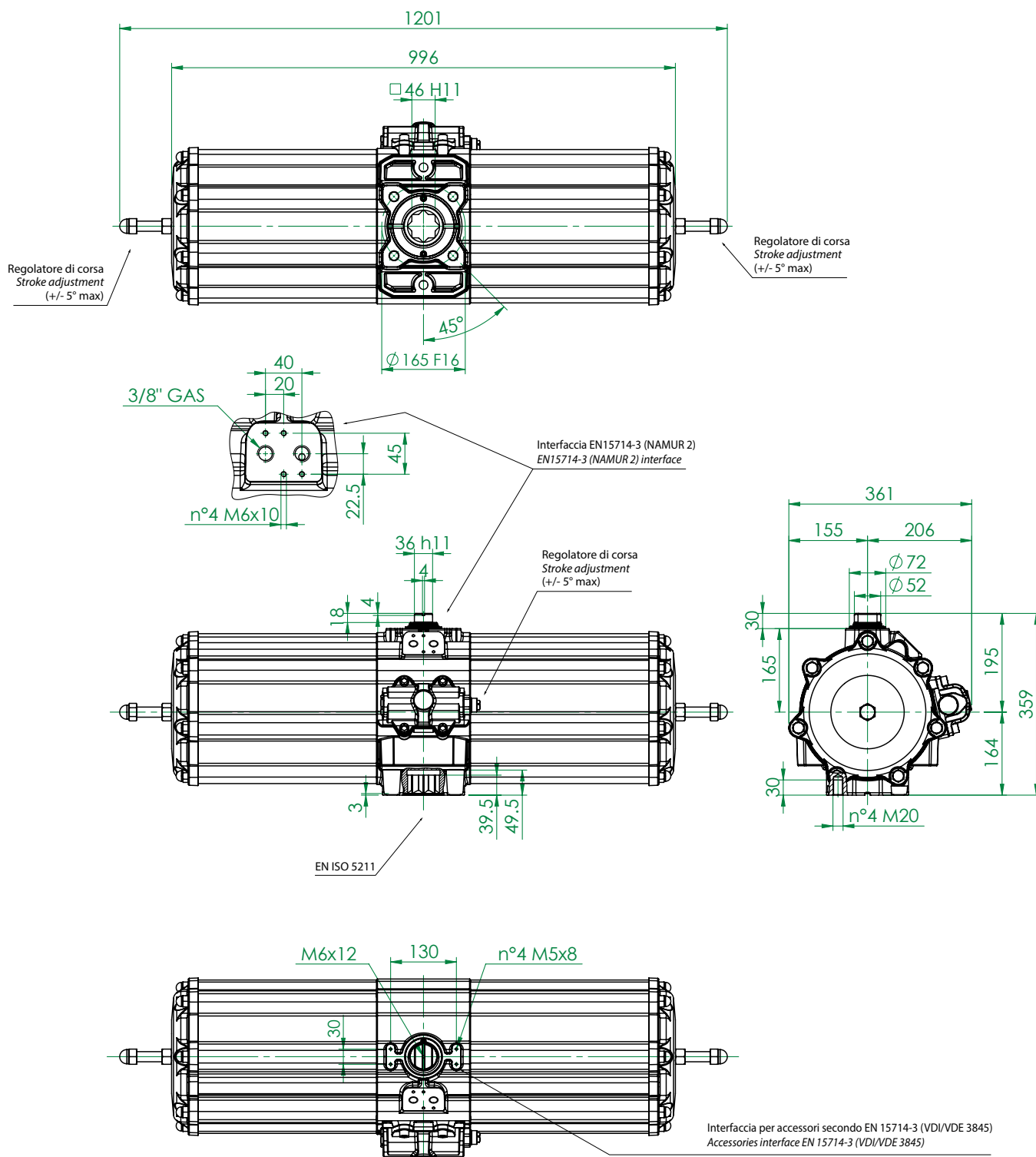

SCHEDA TECNICA DATA SHEET	
Codice Code	GS6288016465
Peso Weight Kg	116,8
Volume aria Air volume $dm^3/cycle$	20,06
Guarnizioni di ricambio Spare seals	KGSI2035



Semplice effetto: **GS 4000 (Nm)**

Spring return: **GS 4000 (Nm)**

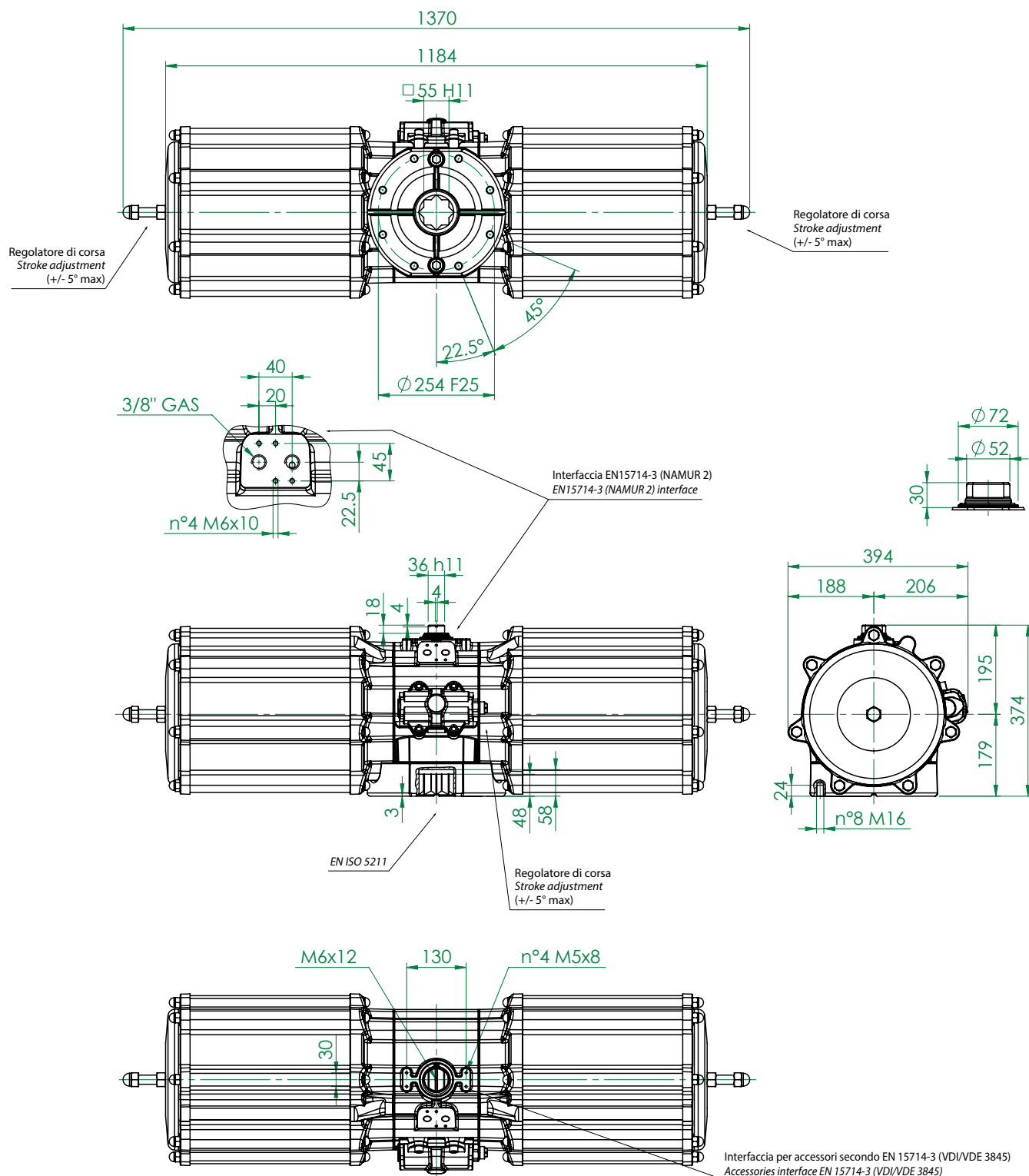

SCHEDA TECNICA DATA SHEET

Codice Code		GS6400025555
Peso Weight	Kg	183,0
Volume aria Air volume	dm ³ /cycle	27,73
Guarnizioni di ricambio Spare seals		KGSI1040





COMPONENTI SEMPLICE EFFETTO: GS 15 ÷ GS 960
SPRING RETURN COMPONENTS: GS 15 ÷ GS 960

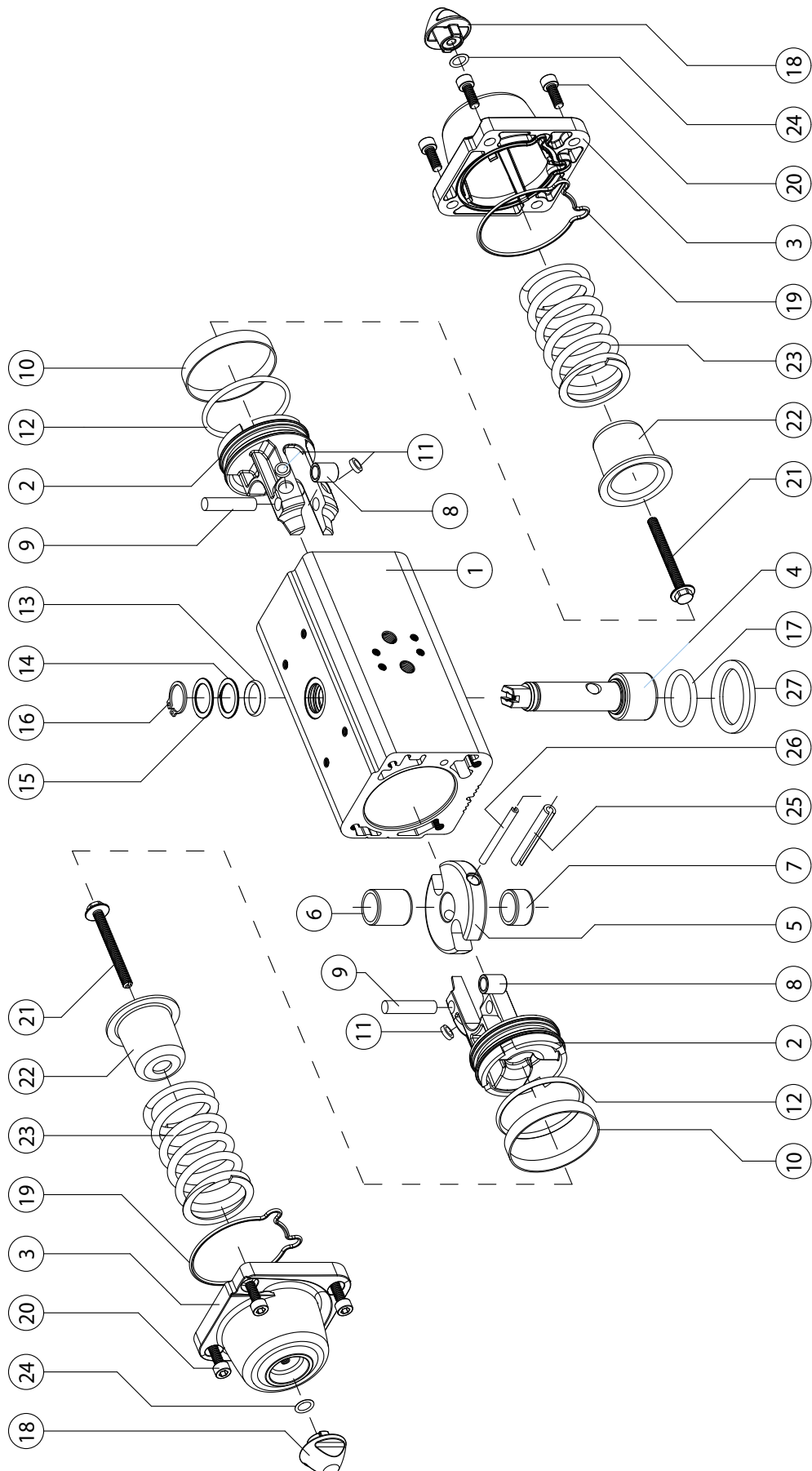



MATERIALI MATERIALS			Materiale Material
Pos	Denominazione Denomination	Q.ty	
1	Cilindro Cylinder	1	Lega di alluminio Aluminium alloy
2	Pistone Piston	2	Lega di alluminio Aluminium alloy
3	Tappo Cap	2	Lega di alluminio Aluminium alloy
4	Albero Shaft	1	Acciaio inox Stainless steel
5	Forcella Scotch yoke	1	Lega di acciaio Steel alloy
6	Bussola di scorrimento Support bush	1	Resina acetaltica Acetalic resin
7	Supporto albero Shaft support	1	Resina acetaltica Acetalic resin
8	Bussola Bush	2	Lega di acciaio Steel alloy
9	Perno Rotative sleeve	2	Lega di acciaio Steel alloy
10*	Anello di tenuta Dynamic seal	2	Poliuretano Polyurethan
11*	Dischetto di supporto Piston's suport	4	P.T.F.E. carbo-graphite filled
12*	O-ring pistone O-ring	2	Gomma nitrilica Nitrilic rubber
13	O-ring albero superiore O-ring (upper sealing shaft)	1	FKM
14	Anello di supporto esterno External support ring	1	Resina acetaltica Acetalic resin
15	Rondella di spessoramento Washer	1	Acciaio inox Stainless steel
16	Seeger	1	Acciaio inox Stainless steel
17	O-ring albero inferiore O-ring (lower sealing shaft)	1	FKM
18	Dado Nut	2	Lega di alluminio Aluminium alloy
19*	O-ring del tappo End-cap O-ring	2	Gomma nitrilica Nitrilic rubber
20	Viti Screws	8	Acciaio inox Stainless steel
21	Viti di precarica molla Spring loading screw	2	Lega di acciaio Steel alloy
22	Contentitore molla Spring cap	2	Lega di acciaio Steel alloy
23	Molla Spring	2	Lega di acciaio Steel alloy
24*	O-ring	2	Gomma nitrilica Nitrilic rubber
25	Spina elastica esterna External elastic pin of the yoke	1	Lega di acciaio Steel alloy
26	Spina elastica interna Internal elastic pin of the yoke	1	Lega di acciaio Steel alloy
27	Anello di centraggio Centering ring (OPTIONAL)	1	Lega di alluminio Aluminium alloy

* Particolari del kit di ricambio Components of spare part-kit



COMPONENTI SEMPLICE EFFETTO: GS 1440

SPRING RETURN COMPONENTS: GS 1440

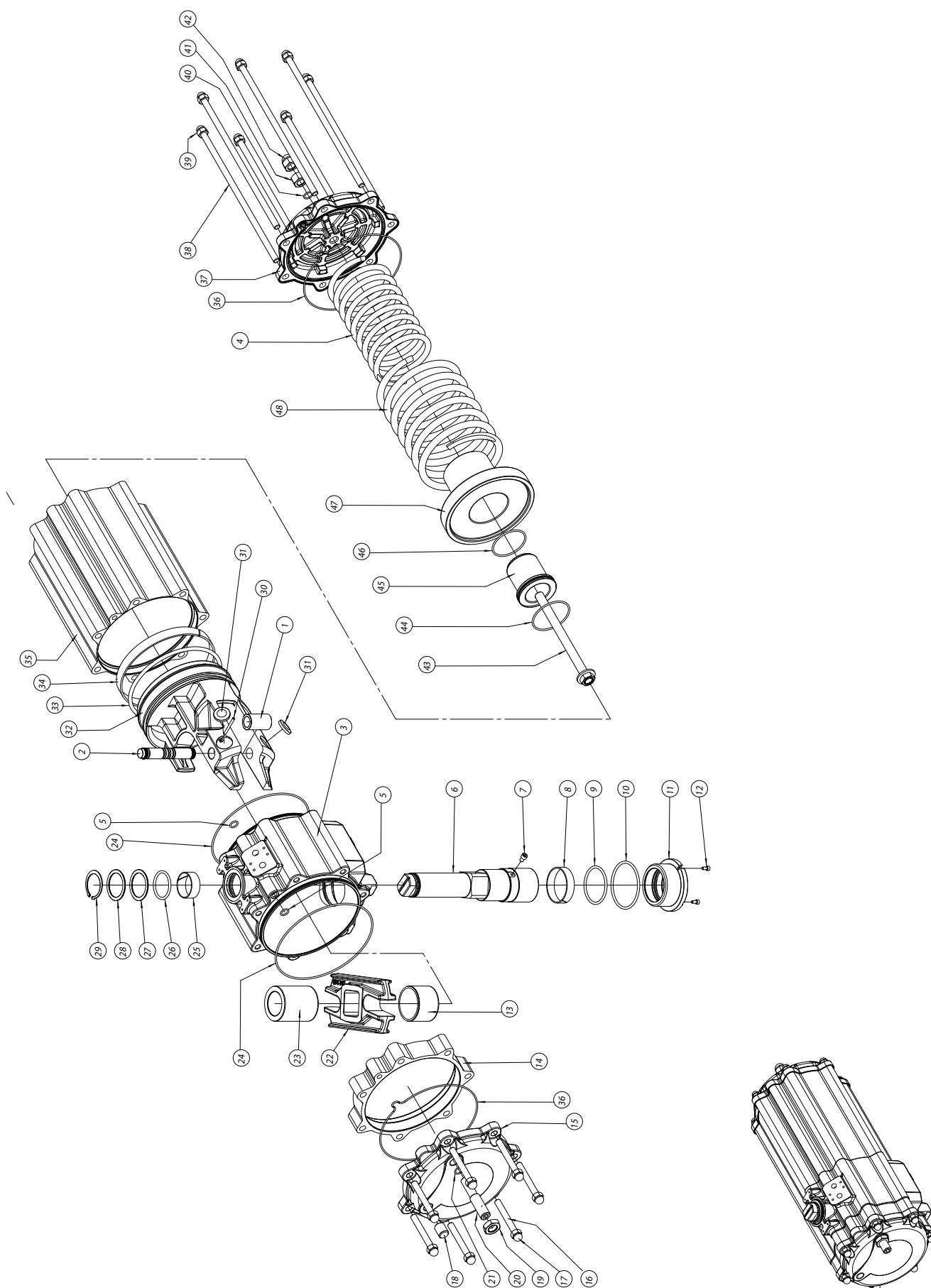



MATERIALI MATERIALS			
Pos	Denominazione	Q.ty	Materiale Material
1	Bussola acciaio Steel bush	1	Acciaio Steel alloy
2	Spina acciaio Steel pin	1	Acciaio Steel alloy
3	Corpo Body	1	Alluminio Aluminium
4	Molla interna Internal spring	1	Acciaio Steel alloy
5*	O-ring	2	Gomma nitrilica Nitrilic rubber
6	Albero Shaft	1	Acciaio Steel alloy
7	Vite antiespulsione Screw	1	Acciaio Steel alloy
8*	Supporto inferiore Bearing (shaft bottom)	1	PT.F.E. carbo-graphite filled
9*	O-ring	1	FKM
10*	O-ring	1	FKM
11	Bussola di supporto inferiore Low bearing bush	1	Alluminio Aluminium
12	Vite per bussola Screw	2	Acciaio Steel alloy
13	Bussola di scorrimento Bearing shaft	1	Resina acetaltica Acetalic resin
14	Distanziale Spacer	1	Alluminio Aluminium
15	Tappo Cap	1	Alluminio Aluminium
16	Vite di assemblaggio Cap screw	7	Acciaio Steel alloy
17	Dado a calotta Cap nut	7	Acciaio Steel alloy
18	Grano (tappo) Grub screw	1	Acciaio Steel alloy
19	Dado Nut	1	Acciaio Steel alloy
20	Grano di regolazione Grub screw	1	Acciaio Steel alloy
21*	O-ring	1	Gomma nitrilica Nitrilic rubber
22	Forcella Scotch yoke	1	Acciaio Steel alloy
23	Bussola di scorr./supp Bearing shaft	1	Resina acetaltica Acetalic resin
24*	O-ring	2	Gomma nitrilica Nitrilic rubber

* Particolari del kit di ricambio Components of spare part kit

MATERIALI MATERIALS			
Pos	Denominazione	Q.ty	Materiale Material
25*	Supporto superiore Bearing (shaft top)	1	PT.F.E. carbo-graphite filled
26*	O-ring	1	FKM
27*	Anello di supporto esterno Thrust bearing	1	Resina acetaltica Acetalic resin
28	Rondella di spessoramento Washer	1	Acciaio Steel alloy
29	Seeger	1	Acciaio Steel alloy
30	Spina antiespulsione Spring pin	1	Acciaio Steel alloy
31*	Dischetti Bearing (piston back)	2	Resina acetaltica Acetalic resin
32	Pistone Piston	1	Alluminio Aluminium
33*	O-ring	1	Gomma nitrilica Nitrilic rubber
34*	Anello di guida Bearing (piston head)	1	PT.F.E. Carbo-Graphite filled
35	Cilindro laterale Lateral Cylinder	1	Acciaio Steel alloy
36*	O-ring	2	Gomma nitrilica Nitrilic rubber
37	Tappo Cap	1	Acciaio Steel alloy
38	Vite di assemblaggio Cap screws	7	Acciaio Steel alloy
39	Dado a calotta Nut	7	Acciaio Steel alloy
40*	O-ring	1	Gomma nitrilica Nitrilic rubber
41	Dado Nut	1	Acciaio Steel alloy
42	Dado a calotta Cap Nut	1	Acciaio Steel alloy
43	Vite di precarica molla Screw	1	Acciaio Steel alloy
44	O-ring	1	Gomma nitrilica Nitrilic rubber
45	Cont.molla piccolo Spring cap	1	Alluminio Aluminium
46	O-ring	1	Gomma nitrilica Nitrilic rubber
47	Cont.molla grande Spring cup	1	Alluminio Aluminium
48	Molla esterna External spring	1	Acciaio Steel alloy

* Particolari del kit di ricambio Components of spare part kit



COMPONENTI SEMPLICE EFFETTO: GS 1920

SPRING RETURN COMPONENTS: GS 1920

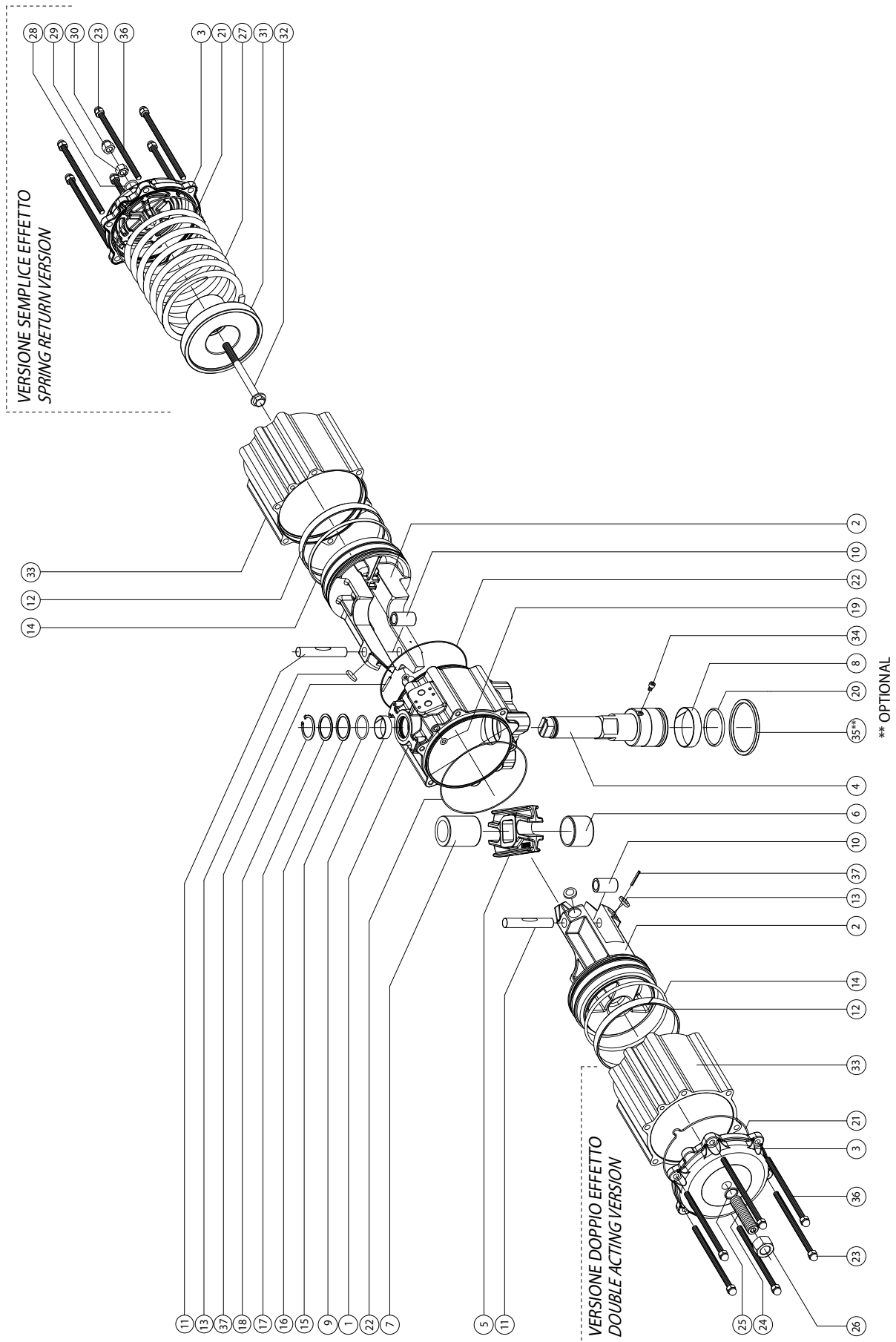



MATERIALI MATERIALS			
Pos	Denominazione Denomination	Q.ty	Materiale Material
1	Cilindro Cylinder	1	Lega di alluminio Aluminium alloy
2	Pistone Piston	2	Lega di alluminio Aluminium alloy
3	Tappo Cap	2	Lega di alluminio Aluminium alloy
4	Albero Shaft	1	Acciaio Inox Stainless steel
5	Forcella Scotch yoke	1	Lega di acciaio Steel alloy
6	Bussola di scorrimento Bearing shaft	1	Resina acetica Acetalic resins
7	Bussola scorrim/supporto Bearing shaft	1	Resina acetica Acetalic resins
8	Fascetta supp.infer. Bearing (shaft bottom)	1	PTFE. carbo-graphite filled
9	Fascetta supp.super. Bearing (shaft top)	1	PTFE. carbo-graphite filled
10	Bussola acciaio Steel bush	2	Lega di acciaio Steel alloy
11	Spina acciaio Steel pin	2	Lega di acciaio Steel alloy
12	Anello di guida Bearing (piston head)	2	PTFE. Carbo-Graphite filled
13*	Dischetto supporto Bearing (piston back)	4	Resina acetica Acetalic resins
14*	O-ring del pistone O-ring	2	Gomma nitrilica Nitrilic rubber
15*	O-ring albero sup. O-ring	1	FKM
16	Anello supporto est. Thrust bearing	1	Resina acetica Acetalic resins
17	Rondella spessoramento Washer	1	Acciaio inox Stainless steel
18	Seeger	1	Acciaio inox Stainless steel
19*	O-ring condaria O-ring	2	Gomma nitrilica Nitrilic rubber

* Particolari del kit di ricambio Components of spare part kit

MATERIALI MATERIALS			
Pos	Denominazione Denomination	Q.ty	Materiale Material
20*	O-ring albero inferiore O-ring	1	FKM
21*	O-ring tappo O-ring	2	Gomma nitrilica Nitrilic rubber
22*	O-ring corpo-cilindro O-ring	2	Gomma nitrilica Nitrilic rubber
23	Dado a calotta Cap nut	12	Acciaio inox Stainless steel
24	Grano di regolaz. Grub screws	2	Acciaio inox Stainless steel
25*	O-ring grano O-ring	2	Gomma nitrilica Nitrilic rubber
26	Dado Nut	2	Acciaio inox Stainless steel
27	Molla Spring	4	Lega di acciaio Steel alloy
28*	O-ring regolazione O-ring	2	Gomma nitrilica Nitrilic rubber
29	Dado Nut	2	Acciaio inox Stainless steel
30	Dado a calotta Cap nut	2	Acciaio inox Stainless steel
31	Contentitore molla Spring cap	2	Lega di alluminio Aluminium alloy
32	Vite di prec.molla Screw	2	Acciaio inox Stainless steel
33	Cilindro laterale Cylinder	2	Lega di alluminio Aluminium alloy
34	Vite antiespulsione Screw	1	Acciaio inox Stainless steel
35**	Anello di centraggio Center ring (OPTIONAL)	1	Lega di alluminio Aluminium alloy
36	Vite di assemblaggio Cap screw	12	Acciaio Steel alloy
37	Spina antiespulsione Spring pin	2	Lega di acciaio Steel alloy

* Particolari del kit di ricambio Components of spare part kit

**OPTIONAL



COMPONENTI SEMPLICE EFFETTO: GS 2880
SPRING RETURN COMPONENTS: GS 2880

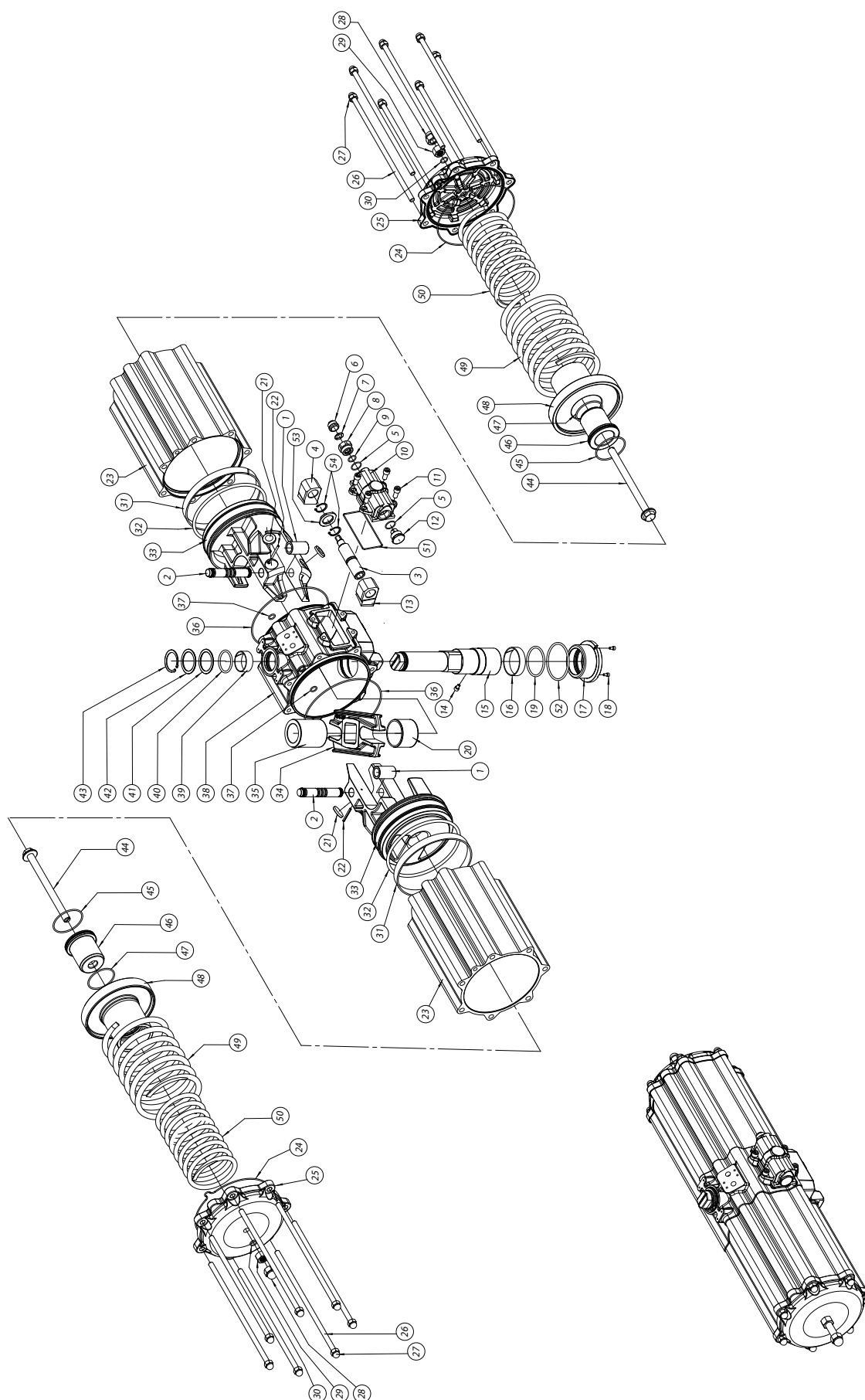



MATERIALI MATERIALS			
Pos	Denominazione	Q.ty	Materiale
28	Dado a calotta Cap nut	2	Acciaio Steel alloy
29	Dado Nut	2	Acciaio Steel alloy
30*	O-ring	2	Gomma nitrilica Nitrilic rubber
31*	Anello di guida Bearing (piston head)	2	P.T.F.E. Carbo-Graphite filled
32*	O-ring pistone O-ring	2	Gomma nitrilica Nitrilic rubber
33	Pistone Piston	2	Alluminio Aluminium
34	Forcella Scotch yoke	1	Acciaio Steel alloy
35	Bussola di scorr/supp Bearing shaft	1	Resina acetatica Acetalic resins
36*	O-ring	2	Gomma nitrilica Nitrilic rubber
37*	O-ring	2	Gomma nitrilica Nitrilic rubber
38	Corpo Body	1	Alluminio Aluminium
39*	Supporto superiore Bearing (shaft top)	1	P.T.F.E. carbo-graphite filled
40*	O-ring	1	FKM
41*	Anello di supp.esterno Thrust bearing	1	Resina acetatica Acetalic resins
42	Rondella di spessoram. Washer	1	Acciaio Steel alloy
43	Seeger	1	Acciaio Steel alloy
44	Vite precarica molla Screw	2	Acciaio Steel alloy
45*	O-ring	2	Gomma nitrilica Nitrilic rubber
46	Cont.molla piccolo Spring cap	2	Alluminio Aluminium
47*	O-ring	2	Gomma nitrilica Nitrilic rubber
48	Cont. molla grande Spring cap	2	Alluminio Aluminium
49	Molla esterna External spring	2	Acciaio Steel alloy
50	Molla interna Internal spring	2	Acciaio Steel alloy
51*	Guarnizione carter Gasket	1	Gomma nitrilica Nitrilic rubber
52*	O-ring	1	FKM
53	Rondella di supporto Washer	1	Acciaio Steel alloy
54	Seeger	2	Acciaio Steel alloy

* Particolari del kit di ricambio Components of spare part kit

MATERIALI MATERIALS			
Pos	Denominazione	Q.ty	Materiale
1	Bussola acciaio Steel bush	2	Acciaio Steel alloy
2	Spina acciaio Steel pin	2	Acciaio Steel alloy
3	Vite di regolazione Adjustment screw	1	Acciaio Steel alloy
4	Fermo sinistro Left stop	1	Acciaio Steel alloy
5*	O-ring	2	Gomma nitrilica Nitrilic rubber
6	Tappo di protezione Protection cap	1	Alluminio Aluminium
7	Rondella antirrotazione Antirotation washer	1	Acciaio Steel alloy
8	Ghiera passante Metal ring	1	Acciaio inox Stainless steel
9*	O-ring	1	Gomma nitrilica Nitrilic rubber
10	Carter di regolaz Carter	1	Alluminio Aluminium
11	Vite per carter Screw	4	Acciaio Steel alloy
12	Ghiera cieca Metal ring	1	Acciaio inox Stainless steel
13	Fermo destro Right stop	1	Acciaio Steel alloy
14	Vite antiespulsione Screw	1	Acciaio Steel alloy
15	Albero Shaft	1	Acciaio Steel alloy
16	Supporto inferiore Bearing (shaft bottom)	1	P.T.F.E. carbo-graphite filled
17	Bussola di supporto inferiore low bearing bush	1	Alluminio Aluminium
18	Vite per bussola Screw	2	Acciaio Steel alloy
19*	O-ring	1	FKM
20	Bussola di scorrimento Bearing shaft	1	Resina acetatica Acetalic resins
21*	Dischetti Bearing (piston back)	4	Resina acetatica Acetalic resins
22	Spina antiespulsione Spring pin	2	Acciaio Steel alloy
23	Cilindro Laterale Lateral cylinder	2	Alluminio Aluminium
24*	O-ring tappo O-ring	2	Gomma nitrilica Nitrilic rubber
25	Tappo Cap	2	Alluminio Aluminium
26	Vite di assemblaggio Cap screws	14	Acciaio Steel alloy
27	Dado a calotta Cap nut	14	Acciaio Steel alloy

* Particolari del kit di ricambio Components of spare part kit



COMPONENTI SEMPLICE EFFETTO: GS 4000

SPRING RETURN COMPONENTS: GS 4000

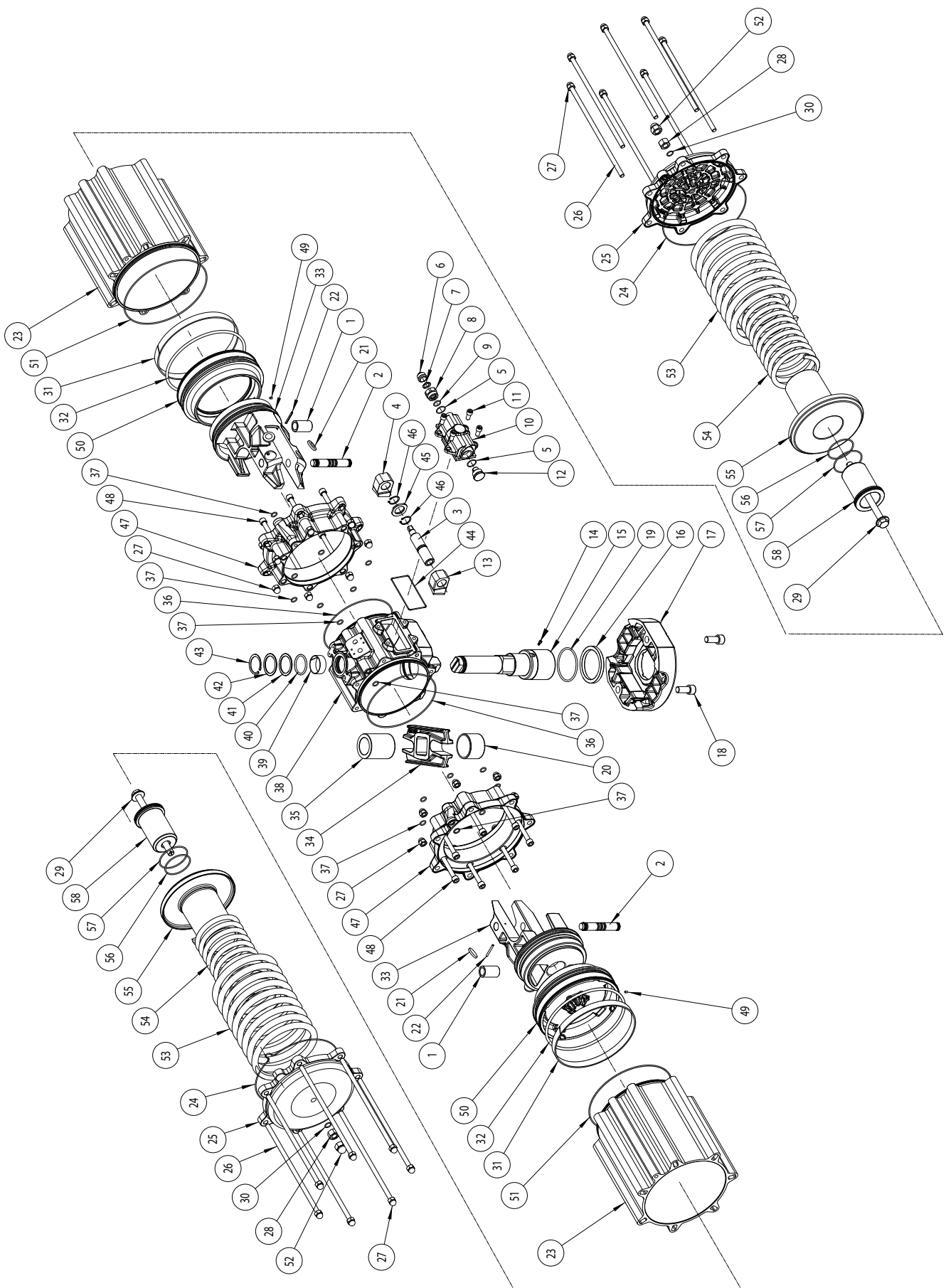



MATERIALI MATERIALS				
Pos	Denominazione	Q.ty	Denominazione	Materiale
30*	O-ring	2		Gomma nitrilica Nitrilic rubber
31*	Anello di guida Bearing (piston head)	2		PT.FE. Carbo-Graphite filled
32*	O-ring pistone O-ring	2		NBR
33	Pistone Piston	2		Alluminio Aluminium
34	Forcella Scotch Yoke	1		Acciaio Steel alloy
35	Bussola di scorr./supp Bearing shaft	1		Resina acetatica Acetalic Resins
36*	O-ring	2		Gomma nitrilica Nitrilic rubber
37*	O-ring	18		Gomma nitrilica Nitrilic rubber
38	Corpo Body	1		Alluminio Aluminium
39*	Supporto superiore Bearing (Shaft top)	1		Resina acetatica Acetalic resins
40*	O-ring	1		FKM
41*	Anello di supp.esterno Thrust bearing	1		Resina acetatica Acetalic resins
42	Rondella di spessore Washer	1		Acciaio Steel alloy
43	Seeger	1		Acciaio Steel alloy
44*	Guarnizione carter Gasket	1		Gomma nitrilica Nitrilic rubber
45	Rondella supporto Washer	1		Acciaio Steel alloy
46	Seeger	2		Acciaio Steel alloy
47	Flangia rid.cilindro Flange	2		Alluminio Aluminium
48	Viti flangia Screw	14		Acciaio Steel alloy
49	Grano Grub screw	2		Acciaio Steel alloy
50	Flangia ridipistone Flange	2		Alluminio Aluminium
51*	O-ring	2		Gomma nitrilica Nitrilic rubber
52	Dado a calotta Cap nut	2		Acciaio Steel alloy
53	Molla esterna External spring	2		Acciaio Steel alloy
54	Molla interna Internal spring	2		Acciaio Steel alloy
55	Cont. molla grande Spring cap	2		Alluminio Aluminium
56	O-ring	2		Gomma nitrilica Nitrilic rubber
57	O-ring	2		Gomma nitrilica Nitrilic rubber
58	Cont.molla piccolo Spring cap	2		Alluminio Aluminium

* Particolari del kit di ricambio Components of spare part kit

MATERIALI MATERIALS				
Pos	Denominazione	Q.ty	Denominazione	Materiale
1	Bussola acciaio Steel bush	2		Acciaio Steel Alloy
2	Spina acciaio Steel pin	2		Acciaio Steel Alloy
3	Vite di regolazione Regulation screw	1		Acciaio Steel Alloy
4	Fermo sinistro Left stop	1		Acciaio Steel Alloy
5*	O-ring	2		Gomma nitrilica Nitrilic rubber
6	Tappo di protezione Protection cap	1		Alluminio Aluminium
7	Rondella antirotazione Antirotation washer	1		Acciaio Steel Alloy
8	Ghiera passante Metal ring	1		Acciaio inox Stainless steel
9*	O-ring	1		Gomma nitrilica Nitrilic rubber
10	Carter di regolaz. Carter	1		Alluminio Aluminium
11	Vite per carter Screw	4		Acciaio Steel Alloy
12	Ghiera cieca Metal ring	1		Acciaio inox Stainless steel
13	Fermo destro Right stop	1		Acciaio Steel Alloy
14	Vite antiespulsione Screw	1		Acciaio Steel Alloy
15	Albero Shaft	1		Acciaio Steel Alloy
16	Supporto inferiore Bearing (shaft bottom)	1		Resina acetatica Acetalic Resins
17	Interfaccia F25 Interface F25	1		Alluminio Aluminium
18	Vite per interfaccia Screw	2		Acciaio Steel Alloy
19*	O-ring	1		FKM
20	Bussola di scorrimento Bearing shaft	1		Resina acetatica Acetalic Resins
21*	Dischetti Bearing (piston back)	4		Resina acetatica Acetalic Resins
22	Spina antiespulsione Spring pin	2		Acciaio Steel Alloy
23	Cilindro laterale Lateral cylinder	2		Alluminio Aluminium
24*	O-ring tappo O-ring	2		Gomma nitrilica Nitrilic rubber
25	Tappo Cap	2		Alluminio Aluminium
26	Vite di assemblaggio Cap screws	14		Acciaio Steel Alloy
27	Dado a calotta Cap nut	28		Acciaio Steel Alloy
28	Dado Nut	2		Acciaio Steel Alloy
29	Vite precarica molla Screw	2		Acciaio Steel Alloy

* Particolari del kit di ricambio Components of spare part kit



SCHEMA FUNZIONAMENTO ATTUATORE PNEUMATICO "GD" WORKING PLANE PNEUMATIC ACTUATOR "GD" TYPE

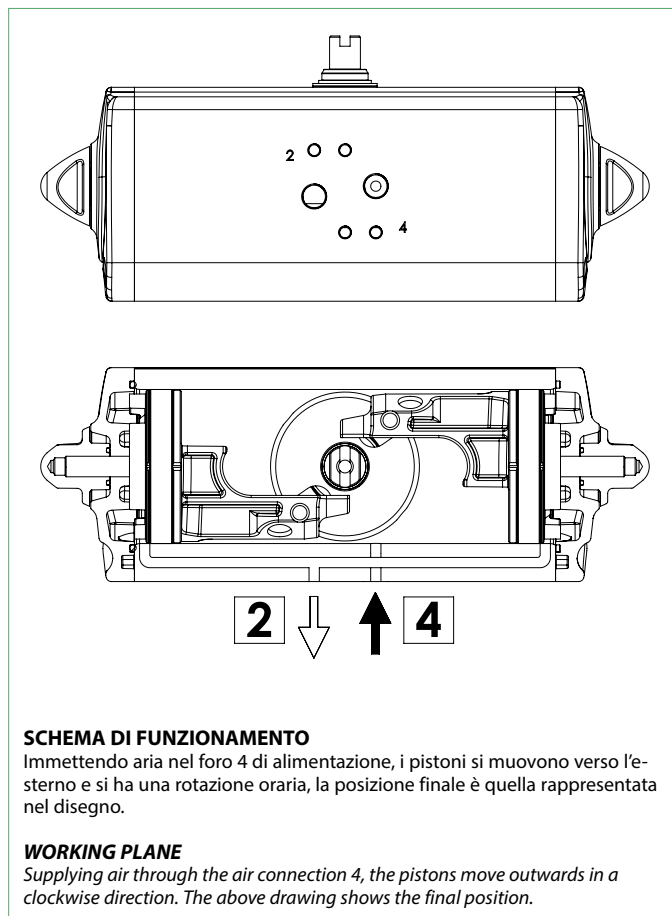
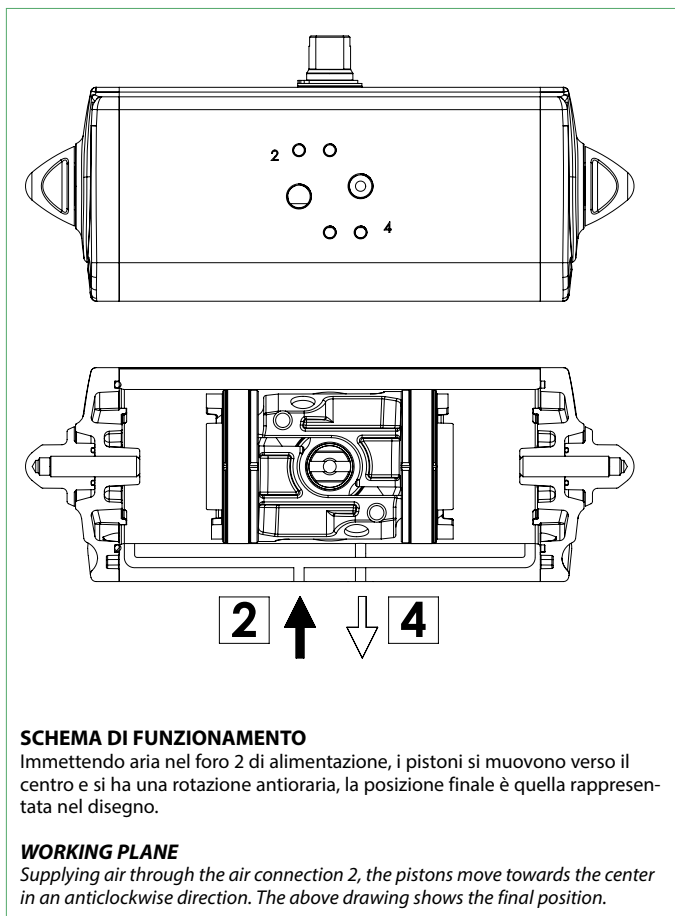

ATTUATORE REGOLABILE-ISTRUZIONI PER L' UTILIZZO ACTUATOR WITH STROKE ADJUSTMENT-INSTRUCTIONS

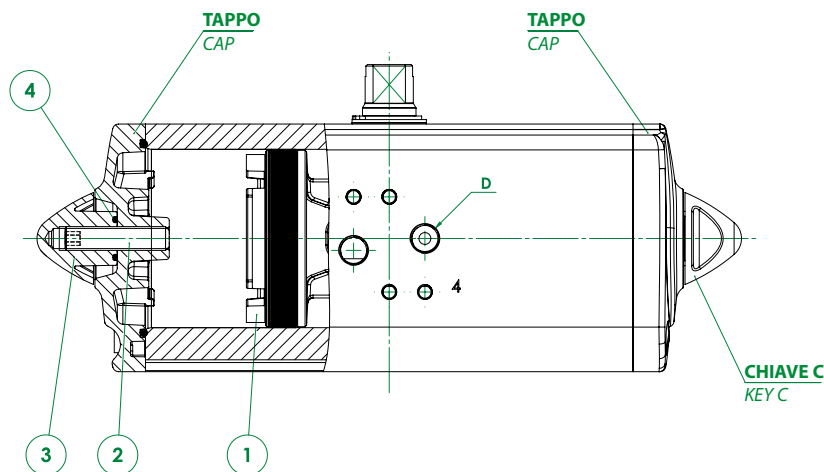

- A)** Immettere aria nel foro "D" in modo che i pistoni (part. n°1) si vengano a trovare in posizione di finecorsa verso i tappi.
B) Togliere il controdado (part. n°3) agendo sulla chiave C.
C) Togliere l'aria di alimentazione.
D) Con una chiave a brugola agire sulle viti (part. n°2) ed effettuare la limitazione di corsa desiderata.
N.B. La corsa può essere limitata per un massimo di 10° da 80° a 90°. Altre regolazioni disponibili a richiesta.
E) Mettere aria nel foro "D", verificare che entrambe le viti (part. n°2) siano a battuta contro i pistoni.
F) Mettere il controdado (part. n°3) munito di O-ring (part. n°4) per la tenuta tra dado e tappo.

N.B. queste spiegazioni sono indicative, per le istruzioni operative, vedere il manuale.

- A)** Supply air through the air connection D so that the pistons (Part. 1) move to the end-stroke position, towards the caps.
B) Remove the counter nut (part. 3) acting on the C key.
C) Shut off the air supply.
D) Adjust the end stroke as desired, acting on the screws (part 2) with an hexagonal key.
Note: maximum adjusting stroke 10°, ranging from 80° to 90°. Other regulations on request.
E) Supply air through the air connection D and check that both screws stop the pistons.
F) Screw the counter-nut (part 3) and its o-ring (part 4) to keep nut and cap tight.

N.B. these explanations are indicative, for operating instructions, see the manual.



SCHEMA FUNZIONAMENTO ATTUATORE PNEUMATICO "GS" WORKING PLANE PNEUMATIC ACTUATOR "GS" TYPE

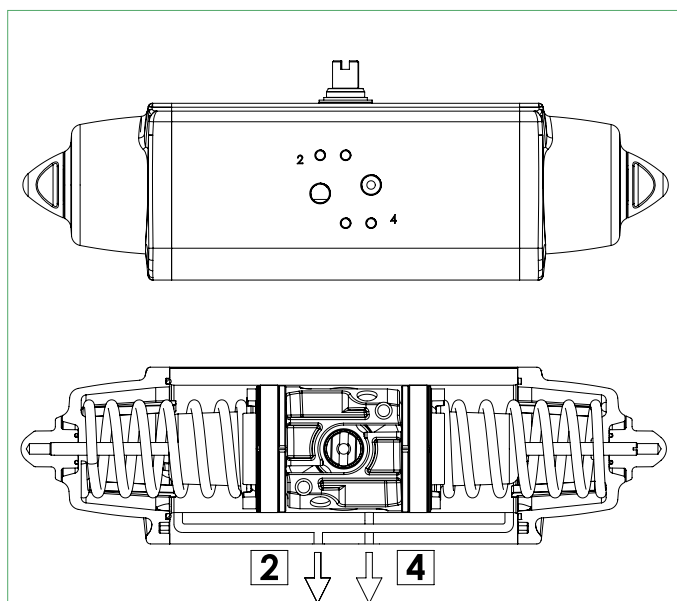

SCHEMA DI FUNZIONAMENTO

Senza pressione di alimentazione, nella versione semplice effetto, l'attuatore torna automaticamente in posizione di riposo compiendo una rotazione oraria e la posizione finale è quella rappresentata nel disegno. Sul foro 2 è consigliato montare un filtrino onde evitare che polvere o particelle solide possano entrare nella camera del cilindro senza tuttavia impedire il passaggio dell'aria.

WORKING PLANE

Without air supply, the spring return actuator returns to its resting position, rotating in a clockwise direction. The drawing shows its final position. We assembling a small filter on the air connection 2 to prevent dust and particles into the cylinder chamber without, however, preventing the passage of air.

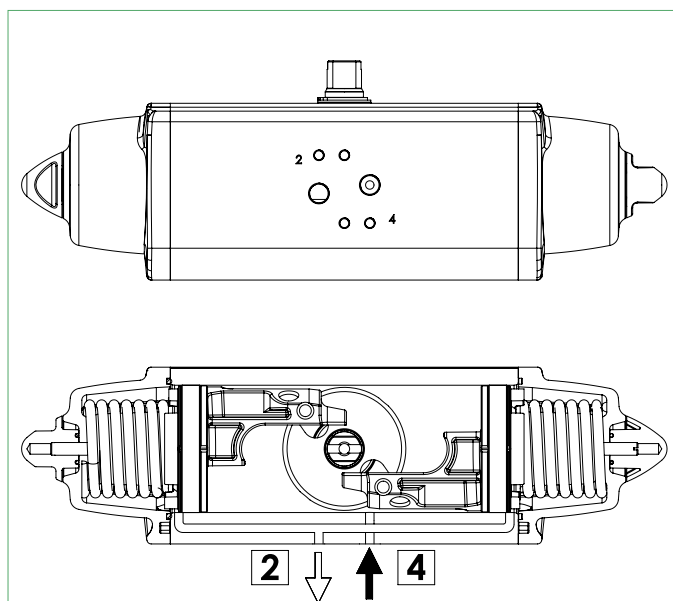

SCHEMA DI FUNZIONAMENTO

Immettendo aria nel foro 4 di alimentazione, i pistoni si muovono verso l'esterno comprimendo le molle, si ha una rotazione antioraria e la posizione finale è quella rappresentata nel disegno.

WORKING PLANE

Supplying air through the air connection 4, the pistons move outwards pressing the spring. An anticlockwise rotation takes place and the final position is shown above.

ATTUATORE REGOLABILE-ISTRUZIONI PER L' UTILIZZO ACTUATOR WITH STROKE ADJUSTMENT-INSTRUCTIONS

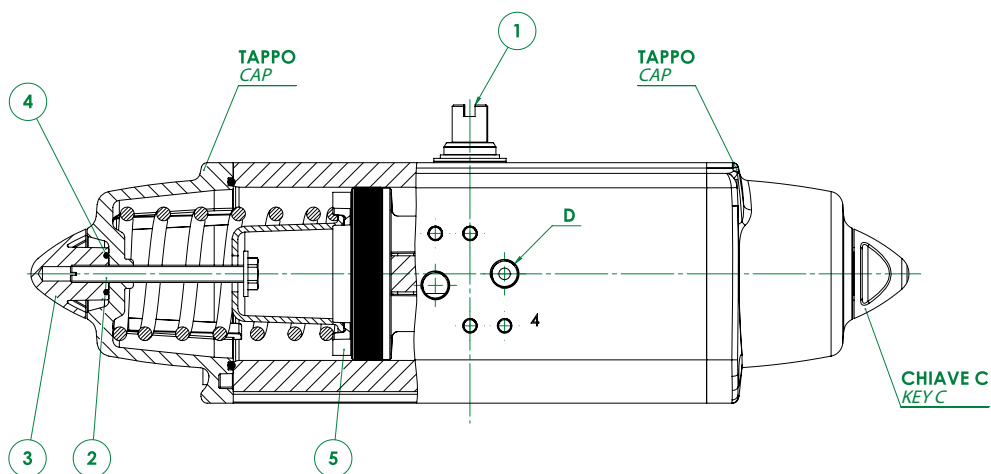

- A) Verificare che le molle siano in posizione di riposo osservando la chiave dell'albero (part. n°1) come da disegno e controllando che nel foro "D" non ci sia pressione.
- B) Togliere i controdadi (part. n°3) agendo sulla chiave C.
- C) Con un cacciavite avvitare le viti (part. n°2) in senso orario ed effettuare la limitazione di corsa desiderata.
- N.B. La corsa può essere limitata per un massimo di 10° da 80° a 90°
- D) Immettere aria nel foro "D" e verificare che entrambe le viti (part. n°2) siano a battuta contro i pistoni (part. n°5).
- E) Bloccare i controdadi (part. n°3) muniti di O-ring (part. n°4) per la tenuta tra controdado, tappo e vite.

N.B. queste spiegazioni sono indicative, per le istruzioni operative, vedere il manuale.

- A) The springs must be at rest position, the shaft (part. 1) must be as shown in the drawing. Air connection D must not be supplied with air.
- B) Remove the counter-nuts (part. 3), acting on key C.
- C) By means of a screwdriver turn screws (part. 2) in a clockwise direction until you obtain the requested end-stroke regulation.
- Note: maximum adjusting stroke 10°, ranging from 80° to 90°.
- D) Supply connection D with air pressure and check that both adjusting screws (part. 2) stop the pistons (part. 5).
- E) Screw the counter-nuts (part. 3) and their O-ring (part. 4) to keep nut and cap tight.

N.B. these explanations are indicative, for operating instructions, see the manual.



VERSIONI SPECIALI A RICHIESTA - ATTUATORI DOPPIO EFFETTO "GD" SPECIAL VERSION ON REQUEST - DOUBLE ACTING "GD" ACTUATORS

I codici indicati fanno riferimento agli attuatori in alluminio. *The codes indicated refer to the aluminium actuator.*

ATTUATORI DOPPIO EFFETTO CON VERNICIATURA EPOSSIDICA DOUBLE ACTING ACTUATOR WITH EPOXY PAINTING										
GD 08 F03	GD 15 F03	GD 15 F04	GD 30 F03-F05	GD 30 F04	GD 45 F04	GD 45 F03-F05	GD 60 F04	GD 60 F05-F07	GD 106 F05-F07	GD 120 F05-F07
GD000080309SV	GD000150311SV	GD000150411SV	GD000300311SV	GD000300411SV	GD000450411SV	GD000450311SV	GD000600414SV	GD000600514SV	GD001060517SV	GD001200517SV
GD 180 F07-F10	GD 240 F07-F10	GD 360 F07-F10	GD 480 F10-F12	GD 720 F10-F12	GD 960 F10-F12	GD 960 F14	GD 1440 F12	GD 1440 F14	GD 1920 F12-F16	GD 1920 F14
GD001800722SV	GD002400722SV	GD003600722SV	GD004801027SV	GD007201027SV	GD009601236SV	GD009601436SV	GD014401236SV	GD014401436SV	GD019201646SV	GD019201446SV

ATTUATORI DOPPIO EFFETTO ALTA TEMPERATURA (-20°C / +150°C) HIGH TEMPERATURE DOUBLE ACTING ACTUATOR (-20°C / +150°C)										
	GD 15 F03	GD 15 F04	GD 30 F03-F05	GD 30 F04	GD 45 F04	GD 45 F03-F05	GD 60 F04	GD 60 F05-F07	GD 106 F05-F07	GD 120 F05-F07
	GD000150311S4	GD000150411S4	GD000300311S4	GD000300411S4	GD000450411S4	GD000450311S4	GD000600414S4	GD000600514S4	GD001060517S4	GD001200517S4
GD 180 F07-F10	GD 240 F07-F10	GD 360 F07-F10	GD 480 F10-F12	GD 720 F10-F12	GD 960 F10-F12	GD 960 F14	GD 1440 F12	GD 1440 F14	GD 1920 F12-F16	GD 1920 F14
GD001800722S4	GD002400722S4	GD003600722S4	GD004801027S4	GD007201027S4	GD009601236S4	GD009601436S4	GD014401236S4	GD014401436S4	GD019201646S4	GD019201446S4

ATTUATORI DOPPIO EFFETTO BASSA TEMPERATURA (-50°C / +60°C) LOW TEMPERATURE DOUBLE ACTING ACTUATOR (-50°C / +60°C)										
	GD 15 F03	GD 15 F04	GD 30 F03-F05	GD 30 F04	GD 45 F04	GD 45 F03-F05	GD 60 F04	GD 60 F05-F07	GD 106 F05-F07	GD 120 F05-F07
	GD000150311S2	GD000150411S2	GD000300311S2	GD000300411S2	GD000450411S2	GD000450311S2	GD000600414S2	GD000600514S2	GD001060517S2	GD001200517S2
GD 180 F07-F10	GD 240 F07-F10	GD 360 F07-F10	GD 480 F10-F12	GD 720 F10-F12	GD 960 F10-F12	GD 960 F14	GD 1440 F12	GD 1440 F14	GD 1920 F12-F16	GD 1920 F14
GD001800722S2	GD002400722S2	GD003600722S2	GD004801027S2	GD007201027S2	GD009601236S2	GD009601436S2	GD014401236S2	GD014401436S2	GD019201646S2	GD019201446S2

A richiesta esecuzioni per taglie superiori *On request executions for larger sizes*



VERSIONI SPECIALI A RICHIESTA - ATTUATORI SEMPLICE EFFETTO "GS" SPECIAL VERSION ON REQUEST - SPRING RETURN "GS" ACTUATORS

I codici indicati fanno riferimento agli attuatori in alluminio. *The codes indicated refer to the aluminium actuator.*

ATTUATORI SEMPLICE EFFETTO CON VERNICIATURA EPOSSIDICA						SPRING RETURN ACTUATOR WITH EPOXY PAINTING				
GS 15 F03-F05	GS 15 F04	GS 30 F04	GS 30 F05-F07	GS 53 F05-F07	GS 60 F05-F07	GS 90 F07-F10	GS 120 F07-F10	GS 180 F07-F10	GS 240 F10-F12	GS 360 F10-F12
GS600150311SV	GS600150411SV	GS600300414SV	GS600300514SV	GS600530517SV	GS600600517SV	GS600900722SV	GS601200722SV	GS601800722SV	GS602401027SV	GS603601027SV
GS 480 F10-F12	GS 480 F14	GS 720 F12	GS 720 F14	GS 960 F12-F16	GS 960 F14					
GS604801236SV	GS604801436SV	GS607201236SV	GS607201436SV	GS609601646SV	GS609601446SV					

ATTUATORI SEMPLICE EFFETTO ALTA TEMPERATURA (-20°C / +150°C)						HIGH TEMPERATURE SPRING RETURN ACTUATOR (-20°C / +150°C)				
GS 15 F03-F05	GS 15 F04	GS 30 F04	GS 30 F05-F07	GS 53 F05-F07	GS 60 F05-F07	GS 90 F07-F10	GS 120 F07-F10	GS 180 F07-F10	GS 240 F10-F12	GS 360 F10-F12
GS600150311S4	GS600150411S4	GS600300414S4	GS600300514S4	GS600530517S4	GS600600517S4	GS600900722S4	GS601200722S4	GS601800722S4	GS602401027S4	GS603601027S4
GS 480 F10-F12	GS 480 F14	GS 720 F12	GS 720 F14	GS 960 F12-F16	GS 960 F14					
GS604801236S4	GS604801436S4	GS607201236S4	GS607201436S4	GS609601646S4	GS609601446S4					

ATTUATORI SEMPLICE EFFETTO BASSA TEMPERATURA (-50°C / +60°C)						LOW TEMPERATURE SPRING RETURN ACTUATOR (-50°C / +60°C)				
GS 15 F03-F05	GS 15 F04	GS 30 F04	GS 30 F05-F07	GS 53 F05-F07	GS 60 F05-F07	GS 90 F07-F10	GS 120 F07-F10	GS 180 F07-F10	GS 240 F10-F12	GS 360 F10-F12
GS600150311S2	GS600150411S2	GS600300414S2	GS600300514S2	GS600530517S2	GS600600517S2	GS600900722S2	GS601200722S2	GS601800722S2	GS602401027S2	GS603601027S2
GS 480 F10-F12	GS 480 F14	GS 720 F12	GS 720 F14	GS 960 F12-F16	GS 960 F14					
GS604801236S2	GS604801436S2	GS607201236S2	GS607201436S2	GS609601646S2	GS609601446S2					

ATTUATORI SEMPLICE EFFETTO 40 PSI ÷ 2,8 bar						SPRING RETURN ACTUATOR 40 PSI ÷ 2,8 bar				
GS 15 F03-F05	GS 15 F04	GS 30 F04	GS 30 F05-F07	GS 53 F05-F07	GS 60 F05-F07	GS 90 F07-F10	GS 120 F07-F10	GS 180 F07-F10	GS 240 F10-F12	GS 360 F10-F12
GS200150311S	GS200150411S	GS200300414S	GS200300514S	GS200530517S	GS200600517S	GS200900722S	GS201200722S	GS201800722S	GS202401027S	GS203601027S
GS 480 F10-F12	GS 480 F14	GS 720 F12	GS 720 F14	GS 960 F12-F16	GS 960 F14					
GS204801236S	GS204801436S	GS207201236S	GS207201436S	GS209601646S	GS209601446S					

ATTUATORI SEMPLICE EFFETTO 50 PSI ÷ 3,5 bar						SPRING RETURN ACTUATOR 50 PSI ÷ 3,5 bar				
GS 15 F03-F05	GS 15 F04	GS 30 F04	GS 30 F05-F07	GS 53 F05-F07	GS 60 F05-F07	GS 90 F07-F10	GS 120 F07-F10	GS 180 F07-F10	GS 240 F10-F12	GS 360 F10-F12
GS300150311S	GS300150411S	GS300300414S	GS300300514S	GS300530517S	GS300600517S	GS300900722S	GS301200722S	GS301800722S	GS302401027S	GS303601027S
GS 480 F10-F12	GS 480 F14	GS 720 F12	GS 720 F14	GS 960 F12-F16	GS 960 F14					
GS304801236S	GS304801436S	GS307201236S	GS307201436S	GS309601646S	GS309601446S					

ATTUATORI SEMPLICE EFFETTO 60 PSI ÷ 4,2 bar						SPRING RETURN ACTUATOR 60 PSI ÷ 4,2 bar				
GS 15 F03-F05	GS 15 F04	GS 30 F04	GS 30 F05-F07	GS 53 F05-F07	GS 60 F05-F07	GS 90 F07-F10	GS 120 F07-F10	GS 180 F07-F10	GS 240 F10-F12	GS 360 F10-F12
GS400150311S	GS400150411S	GS400300414S	GS400300514S	GS400530517S	GS400600517S	GS400900722S	GS401200722S	GS401800722S	GS402401027S	GS403601027S
GS 480 F10-F12	GS 480 F14	GS 720 F12	GS 720 F14	GS 960 F12-F16	GS 960 F14					
GS404801236S	GS404801436S	GS407201236S	GS407201436S	GS409601646S	GS409601446S					

A richiesta esecuzioni per taglie superiori *On request executions for larger sizes*



ACCESSORI ATTUATORI PNEUMATICI PNEUMATIC ACTUATOR ACCESSORIES

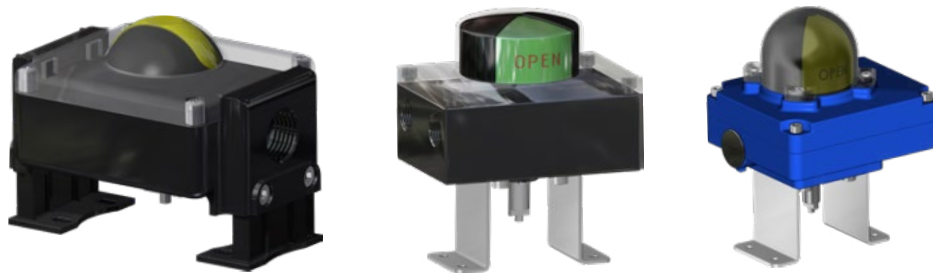

BOX DI SEGNALAZIONE CON FINECORSO
LIMIT SWITCH BOX



OPERATORE MANUALE DI SBLOCCO
MANUAL OVERRIDE WITH HAND WHEEL



ELETTROVALVOLE
SOLENOID VALVES



ELETTROVALVOLE NAMUR
NAMUR SOLENOID VALVES



POSIZIONATORE PNEUMATICO
PNEUMATIC POSITIONER



POSIZIONATORE ELETTROPNEUMATICO
(SICUREZZA INTRINSECA)
ELECTROPNEUMATIC POSITIONER
(INTRINSICALLY SAFE)



FINECORSA DI PROSSIMITA'
PROXIMITY LIMIT SWITCHES



FINECORSA ELETTROMECCANICI
ELECTROMECHANICAL LIMIT SWITCHES

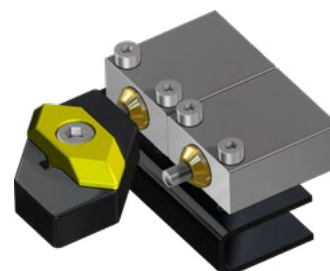

FINECORSA PNEUMATICI
PNEUMATIC LIMIT SWITCHES

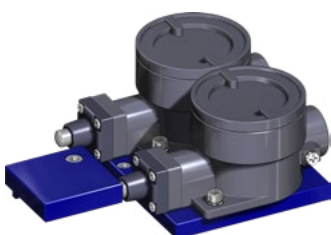

FINECORSA ANTIDEFLAGRANTI II2GD ExdIIC
EXPLOSION PROOF LIMIT SWITCHES II2GD ExdIIC

Per maggiori informazioni consultare **Catalogo Accessori ACTUATECH.**
For more information check the **ACTUATECH Accessories Catalogue.**



CERTIFICAZIONI ATTUATORI ALLUMINIO ALUMINIUM ACTUATORS CERTIFICATES



▲ **ACKNOWLEDGEMENT OF RECEIPT - EC - ATEX**



▲ **SIL (Pneumatic actuator certificate)**

Certificazione di conformità alla norma IEC 61508, del livello di sicurezza funzionale del prodotto destinato ad essere integrato in sistemi con un livello di integrità funzionale fino a SIL 3.

Certification in compliance with the IEC 61508 functional safety level requirements, meant for products intended to be integrated in safety integrity level systems up to SIL 3.



▲ **DECLARATION OF DUST AND WATER PROTECTION DEGREE IP6X-IPX8-IPX6**





NOTES:

A large area of dotted lines for writing notes, consisting of 30 horizontal rows of small black dots.



NOTES:

A series of horizontal dotted lines for writing notes, spanning the width of the page.

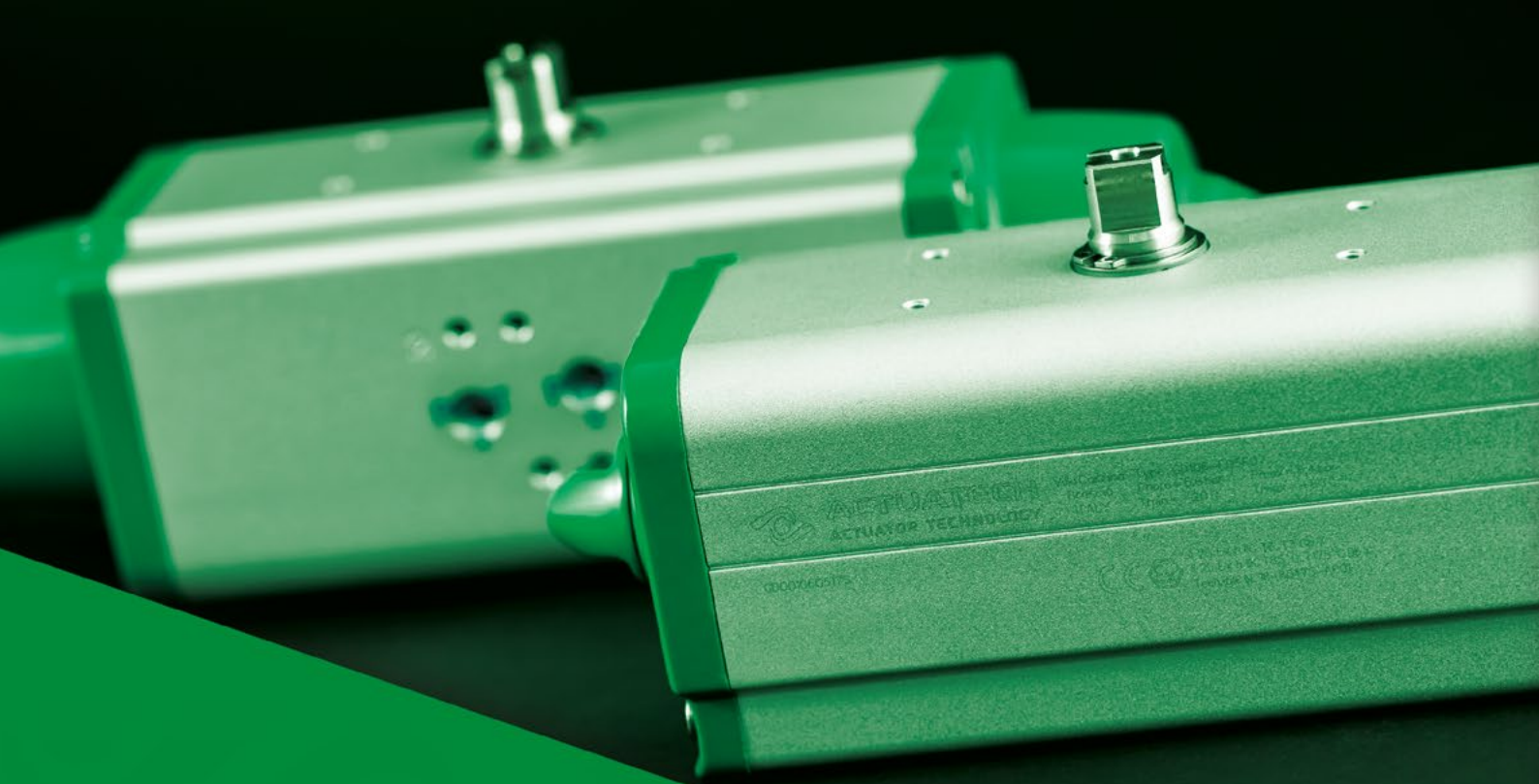

ACTUATECH S.p.A.



Ph. +39 030 8908142 - Fax +39 030 8908143 - actuatech@actuatech.com - www.actuatech.com

VILLA CARCINA HEADQUARTERS

Via San Lorenzo, 70 - 25069 Villa Carcina (BS) ITALY

Coordinates:

Lat: 45° 39' 09.6" North; Lon: 10° 11' 49.5" East

SAREZZO SITE

Via Fratelli Capponi, 126 - 25068 Sarezzo (BS) ITALY

Coordinates:

Lat: 45° 39' 48.5" North; Lon: 10° 11' 39.4" East